



Adult Teaching Suggestions

We hope you find these Pre-Key Stage Standard suggestions useful. Please be aware that the suggestions and resources mentioned are potential ways to check understanding relating to the relevant strands. Other resources may be needed in addition to those suggested.

Strand D – Word Reading

The pupil can read aloud many words quickly and accurately without overt sounding and blending.

Task

Activity One – Phoneme Spotter Stories

Select an appropriate text from the [Phoneme Spotter Story Bumper Story Pack](#) and ask pupils to read it to you aloud. Listen and check for accuracy and fluency, making a note of anything they particularly find difficult.

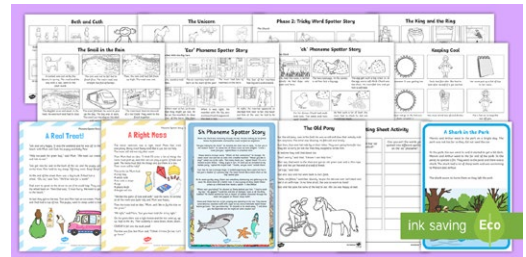

Activity Two – Ronald the Rhino

Ask pupils to read [Ronald the Rhino eBook](#) aloud. Listen and check for accuracy and fluency, making a note of anything they particularly find difficult.

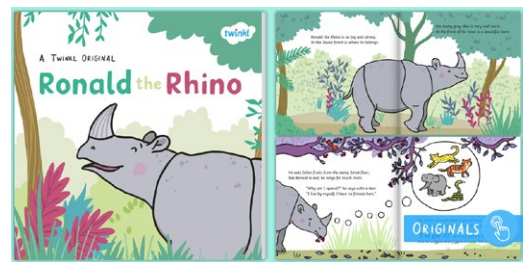

Activity Three – 60 Second Reads

Choose an appropriate text from the [60-Second Reads Bumper Pack](#) and ask pupils to read it to you aloud. Listen and check for accuracy and fluency, making a note of anything they particularly find difficult.

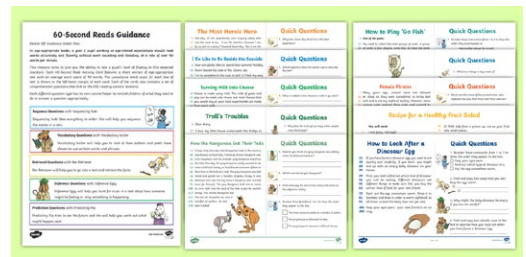

60-Second Reads Guidance

Recent DfE Guidance stated that:

In age-appropriate books, a year 2 pupil working at age-related expectations should read words accurately and fluently without overt sounding and blending, at a rate of over 90 words per minute.

This resource aims to give you the ability to test a pupil's level of fluency to this expected standard. Each 60-Second Read Activity Card features a short extract of age-appropriate text with an average word count of 90 words. The cumulative word count for each line of text is shown in the left-hand margin of each card. Each of the cards also contains a set of comprehension questions that link to the KS1 reading content domains.

Each different question type has its own canine helper to remind children of what they need to do to answer a question appropriately:

Sequence Questions with Sequencing Suki

Sequencing Suki likes everything in order! She will help you sequence the events in a text.



Vocabulary Questions with Vocabulary Victor

Vocabulary Victor will help you to look at how authors and poets have chosen to use certain words and phrases.

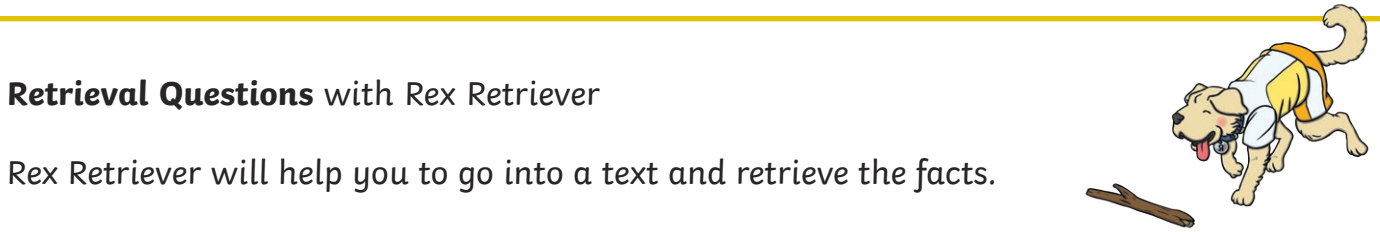

Retrieval Questions with Rex Retriever

Rex Retriever will help you to go into a text and retrieve the facts.



Inference Questions with Inference Iggy

Inference Iggy will help you hunt for clues in a text about how someone might be feeling or why something is happening.

Prediction Questions with Predicting Pip

Predicting Pip tries to see the future and she will help you work out what might happen next.



A TWINKL ORIGINAL

Ronald the Rhino

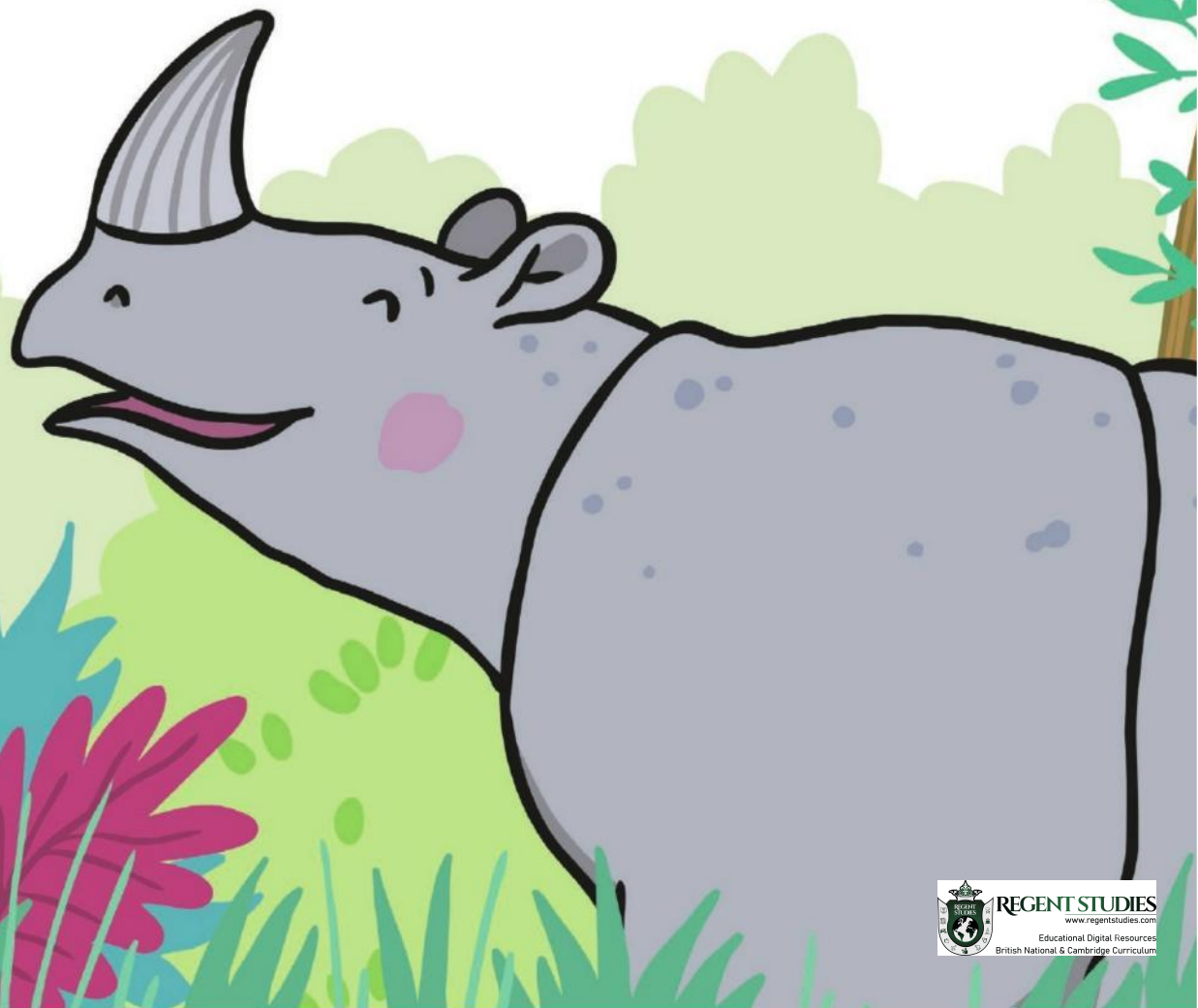





A TWINKL ORIGINAL

Ronald the Rhino

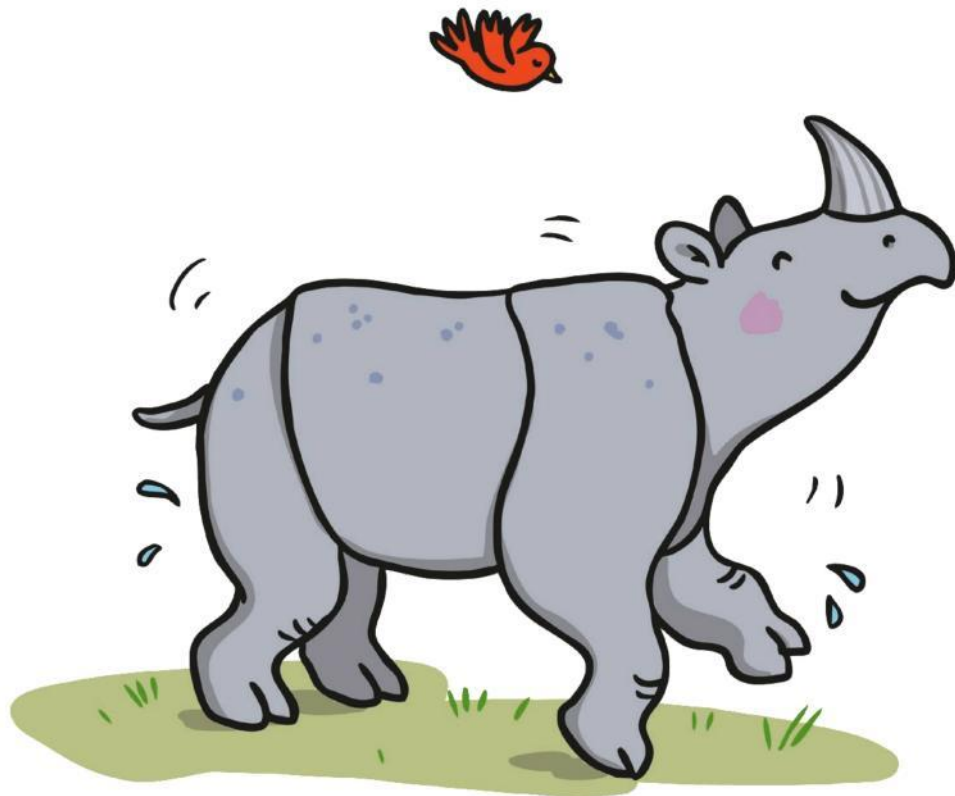

Ronald the Rhino is so big and strong.
In the Javan forest is where he belongs.

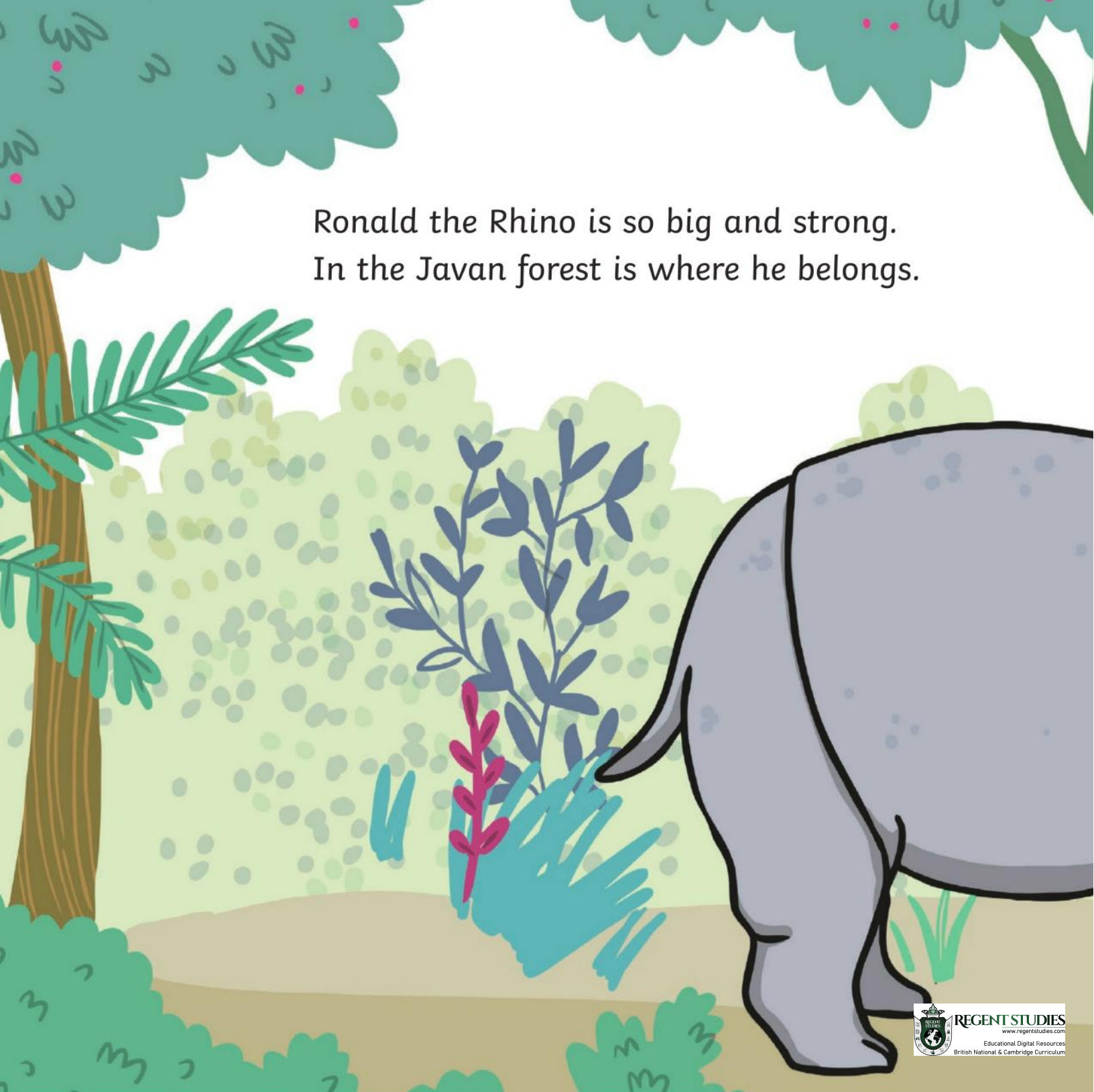

His dusky grey skin is very well worn.
At the front of his head is a beautiful horn.





He eats fallen fruits from the damp forest floor,
But Ronald is sad; he longs for much more.

“Why am I special?” he says with a tear.
“I live by myself, I have no friends here.”





“All of the animals have a grand trait,
Something unique that makes them just great.”

“I’ve got it!” he cries, with a smile on his face,
And he wiggles and jiggles all over the place.

“I’ll be a leopard with beautiful spots,
All yellowish fur and dark brownish dots.”

Ronald sets off to hatch out his plan,
And through the dense forest his eyes start to scan.



He soon finds some mud, all sticky and wet.
“Great!” Ronald says, “I’ll have my spots yet!”

He starts right away, painting on patches,
Using his horn to scoop mud up in batches.



As soon as he's finished, he admires his work,
But high in the trees, Leopard does lurk.

“What are you doing?” Leopard asks with a grin.
“You’ve mud in great patches all over your skin!”

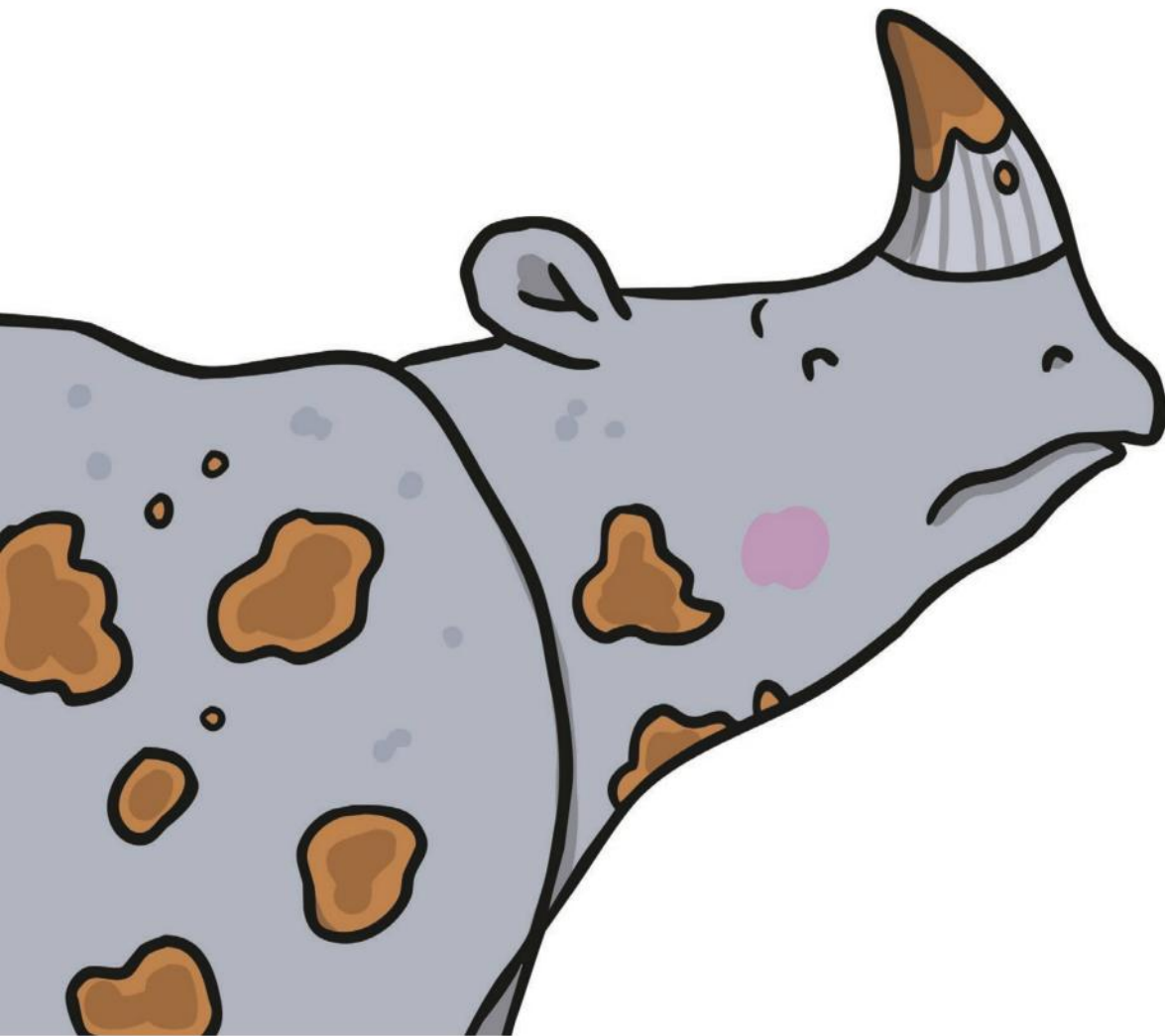



“I want to be like you, with spots on my face,
To sleep in a tree; to run, leap and race!”

“You can’t be a leopard, you’re too big and grey.
You’re a Javan rhino in every way!”

Ronald looks sad, unsure what to do.
He lets out a sigh; he's feeling so blue.

“Why am I special?” he says with a tear.
“I live by myself, I have no friends here.”

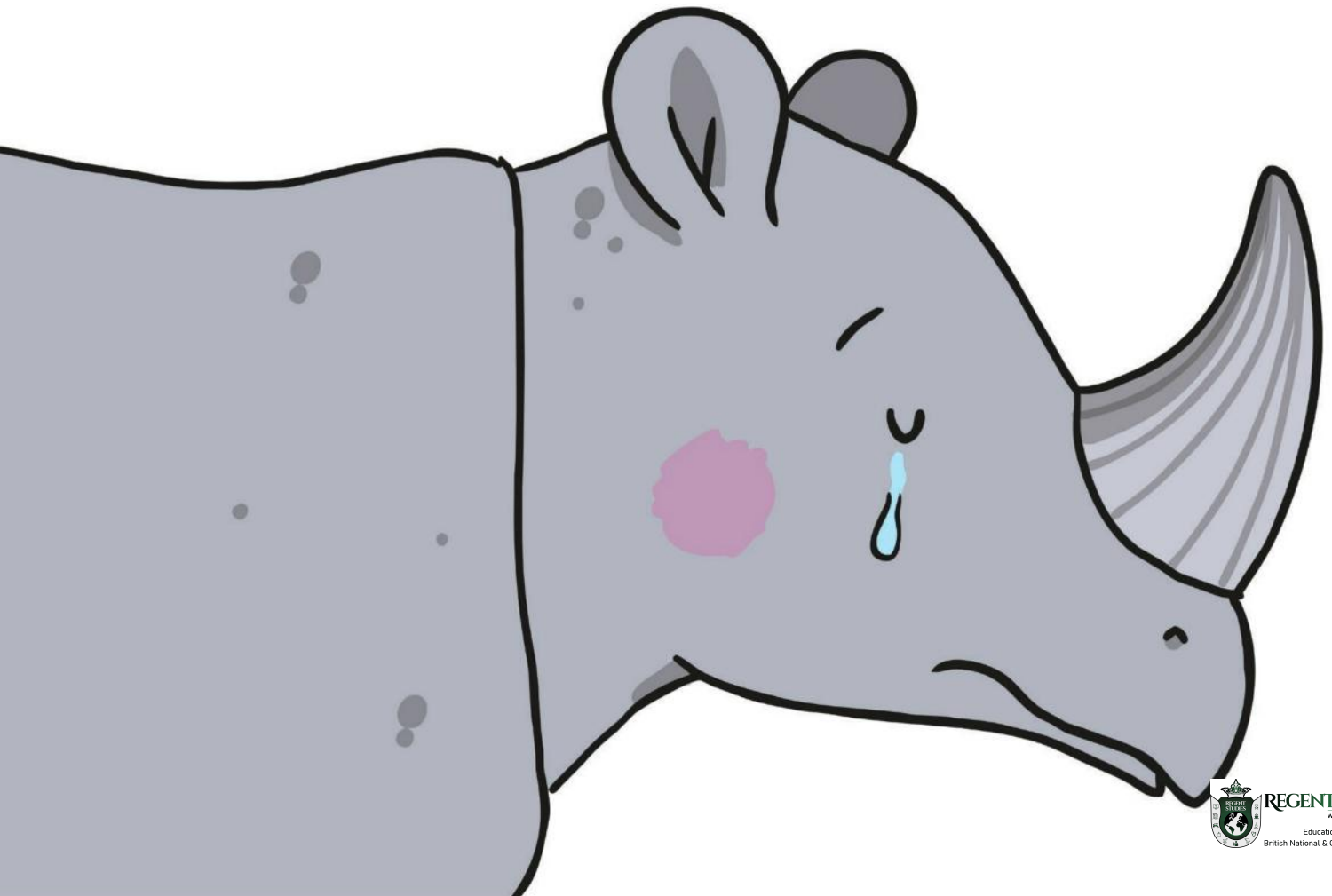

“All of the animals have a grand trait.
Leopard has spots that make him just great.”

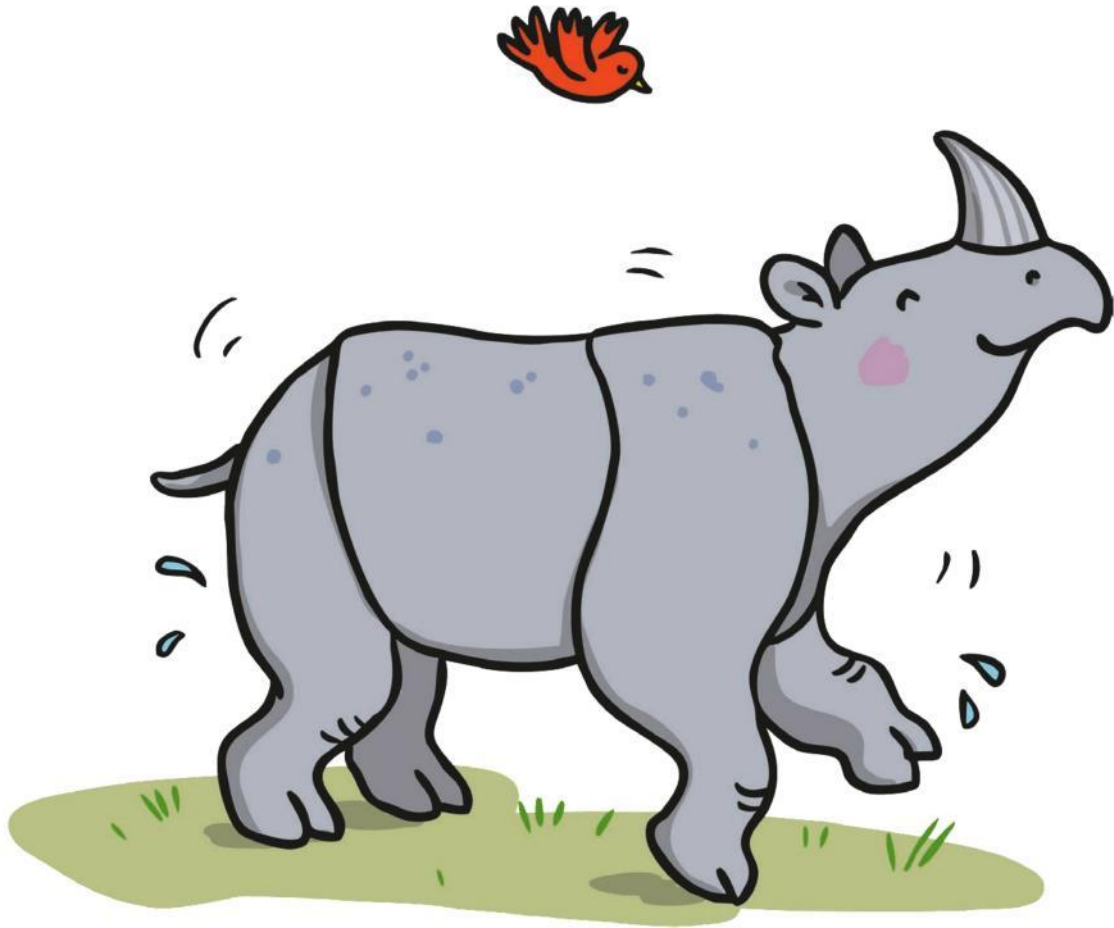

“I’ve got it!” he cries, with a smile on his face,
And he wiggles and jiggles all over the place.

“I’ll be a python, my body so strong,
With smooth patterned skin and a tongue nice and long!”

He starts right away and gets down on the ground.
He slides through the mud with a terrible sound.



But as Ronald moves, he lets out a wail;
His body is sore and bent round like a snail.

Out in the bushes, now Python can see
What the young rhino is trying to be.

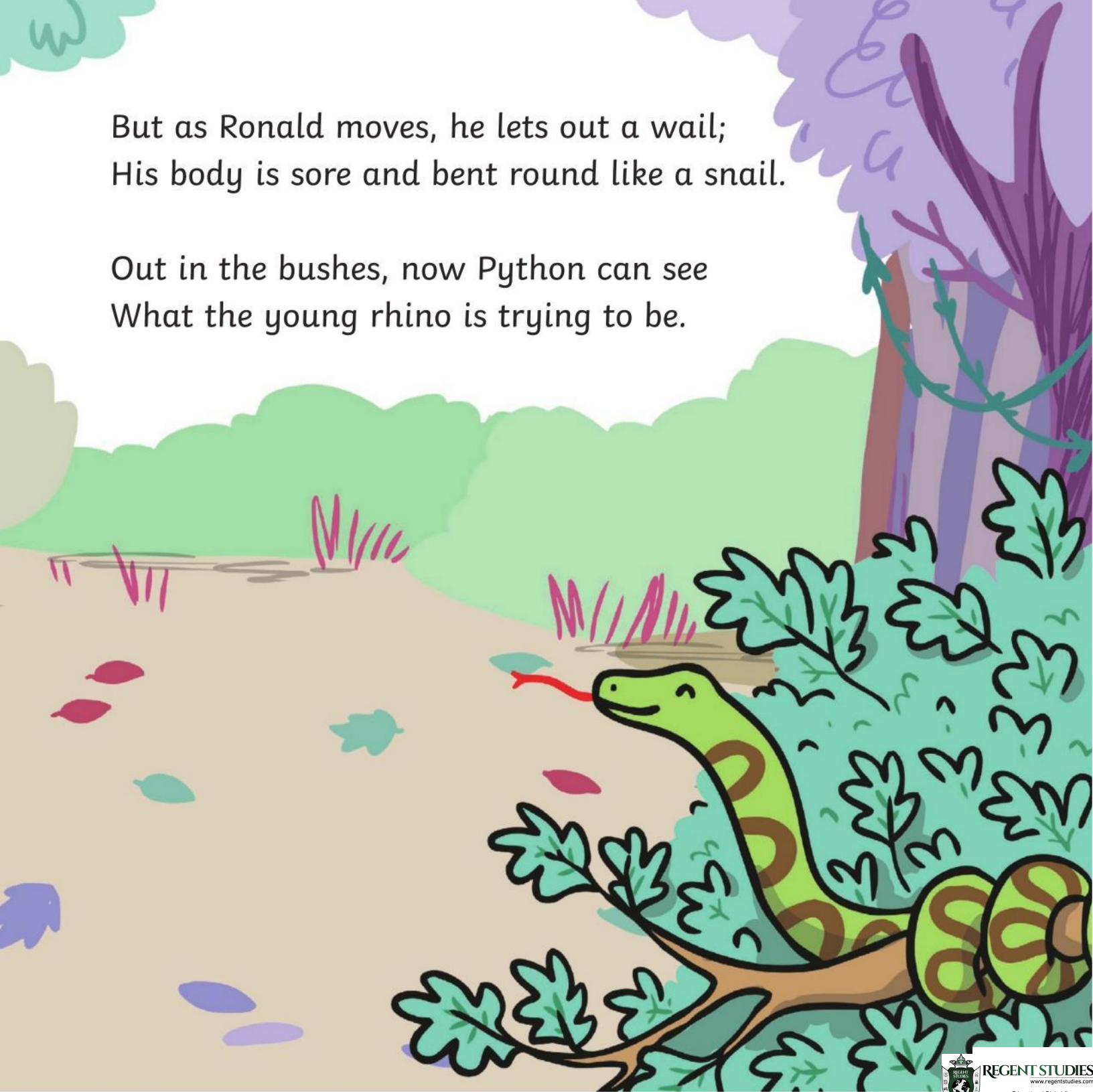

REGENT STUDIES

www.regentstudies.com

Educational Digital Resources
British National & Cambridge Curriculum

“Why are you moving around like a snake?
Your back is all bent; I saw your legs shake!”

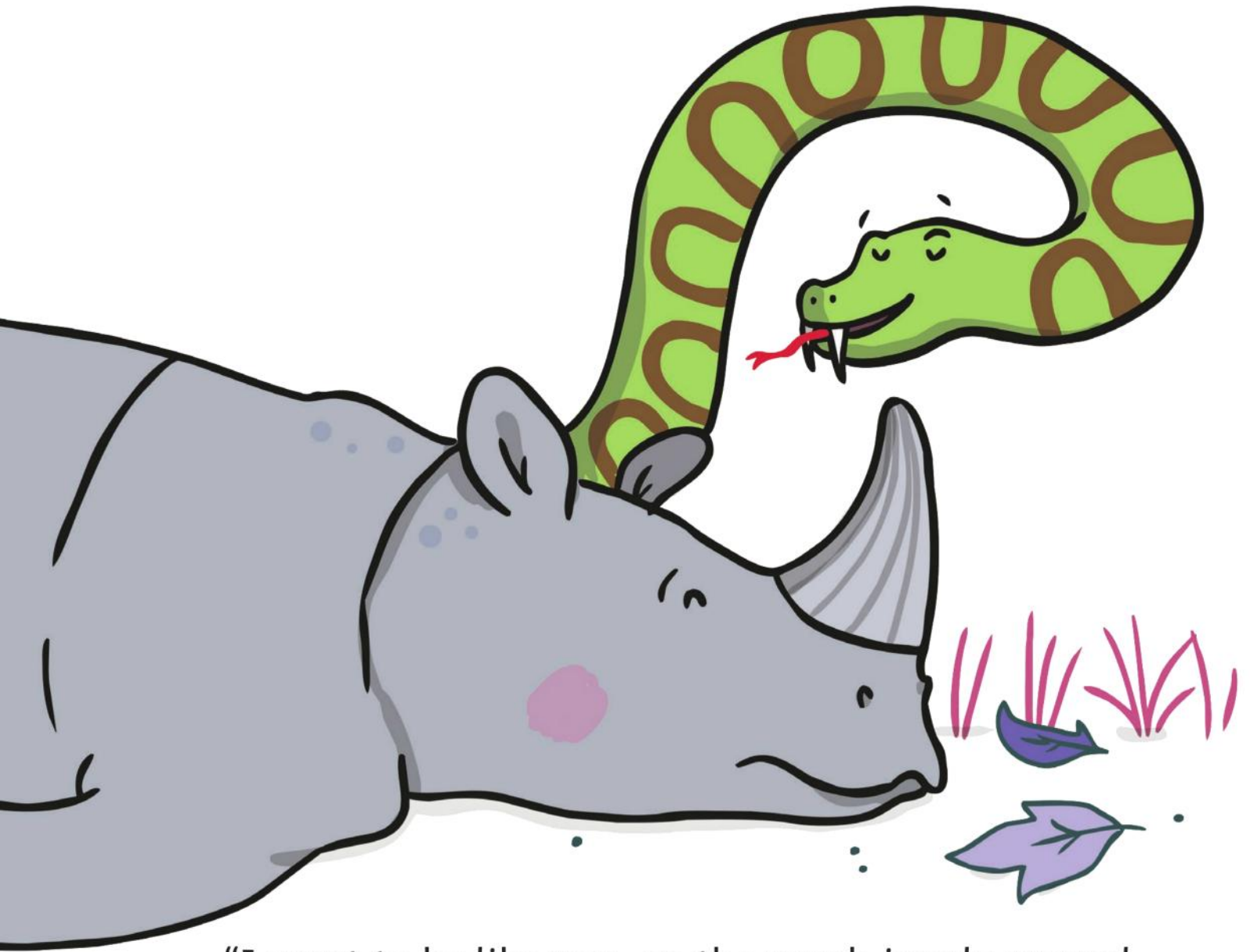

“I want to be like you, on the rough jungle ground,
Slowly and smoothly sliding around.”

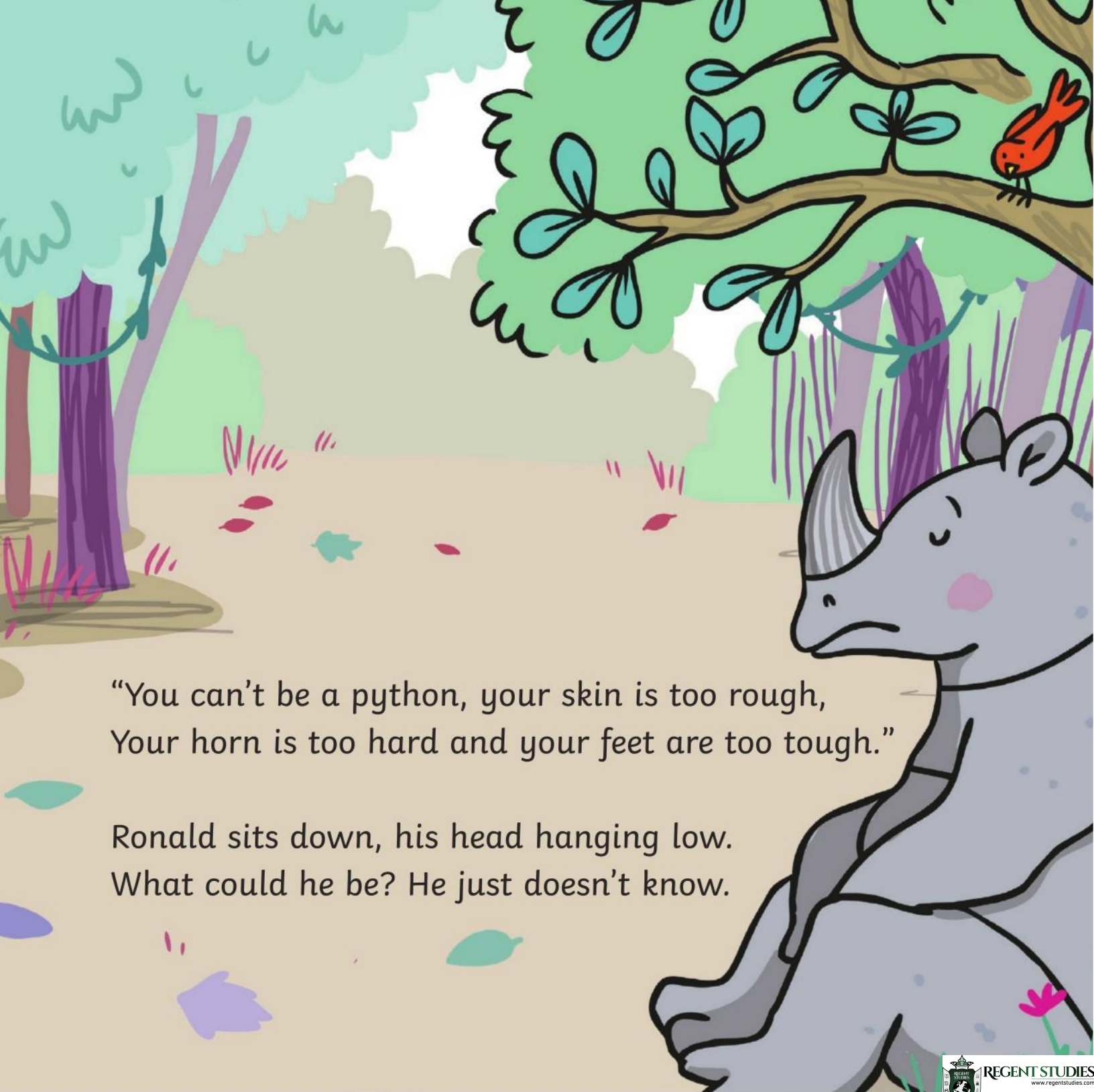

“You can’t be a python, your skin is too rough,
Your horn is too hard and your feet are too tough.”

Ronald sits down, his head hanging low.
What could he be? He just doesn’t know.





“Why am I special?” he says with a tear.
“I live by myself, I have no friends here.

All of the animals have a grand trait.
Python slides smoothly, which makes him just great.”

Leopard and Python see Ronald so glum,
So they cook up a plan to cheer up their chum.

“We’ve got it!” they say, looking down at his face.
Ronald wiggles and jiggles all over the place.

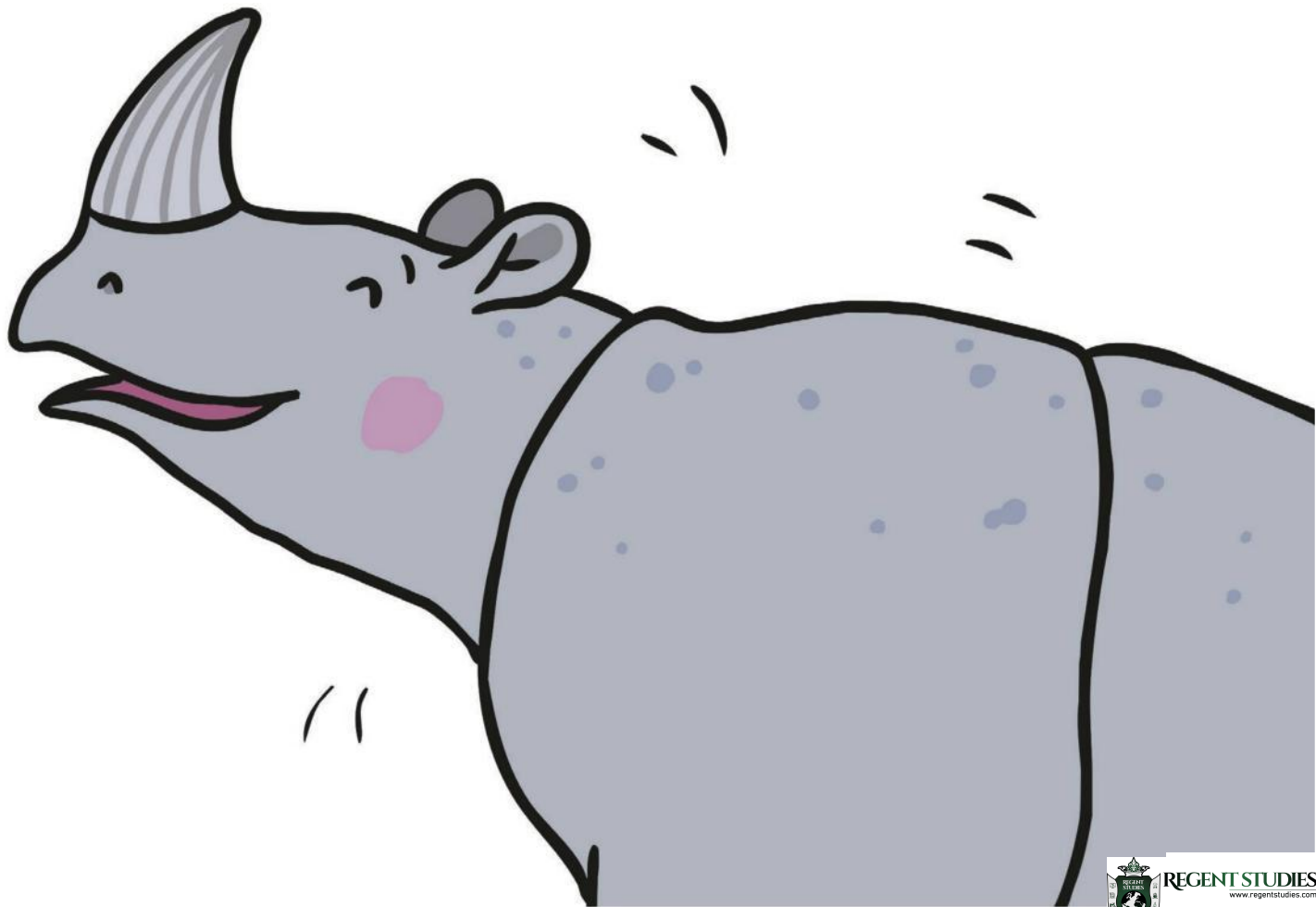

His skin is tough and looks like great armour.
His eyes sparkle brightly – he’s a real charmer!

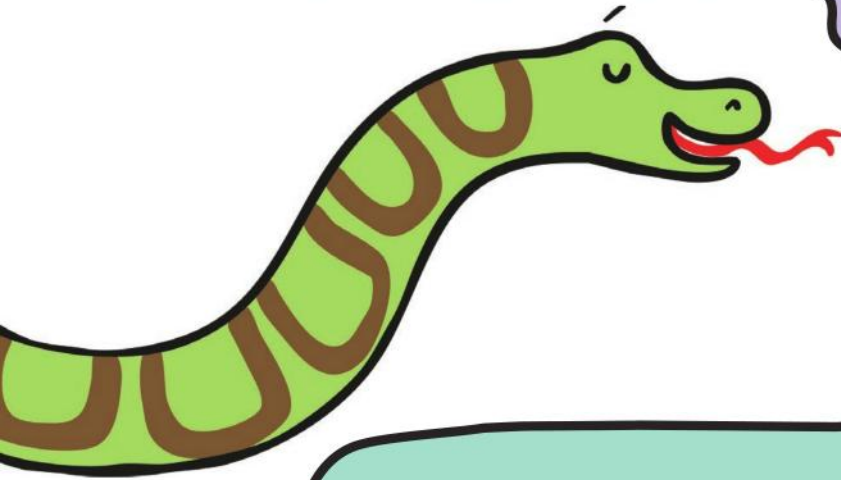

His legs are so strong and his horn is the best.
The animals love him, as you may have guessed.



“I want to be like him!” Ronald cries out,
His eyes shining bright as his feet dance about.

So into the forest they set off to find
This mystery animal that might change his mind.

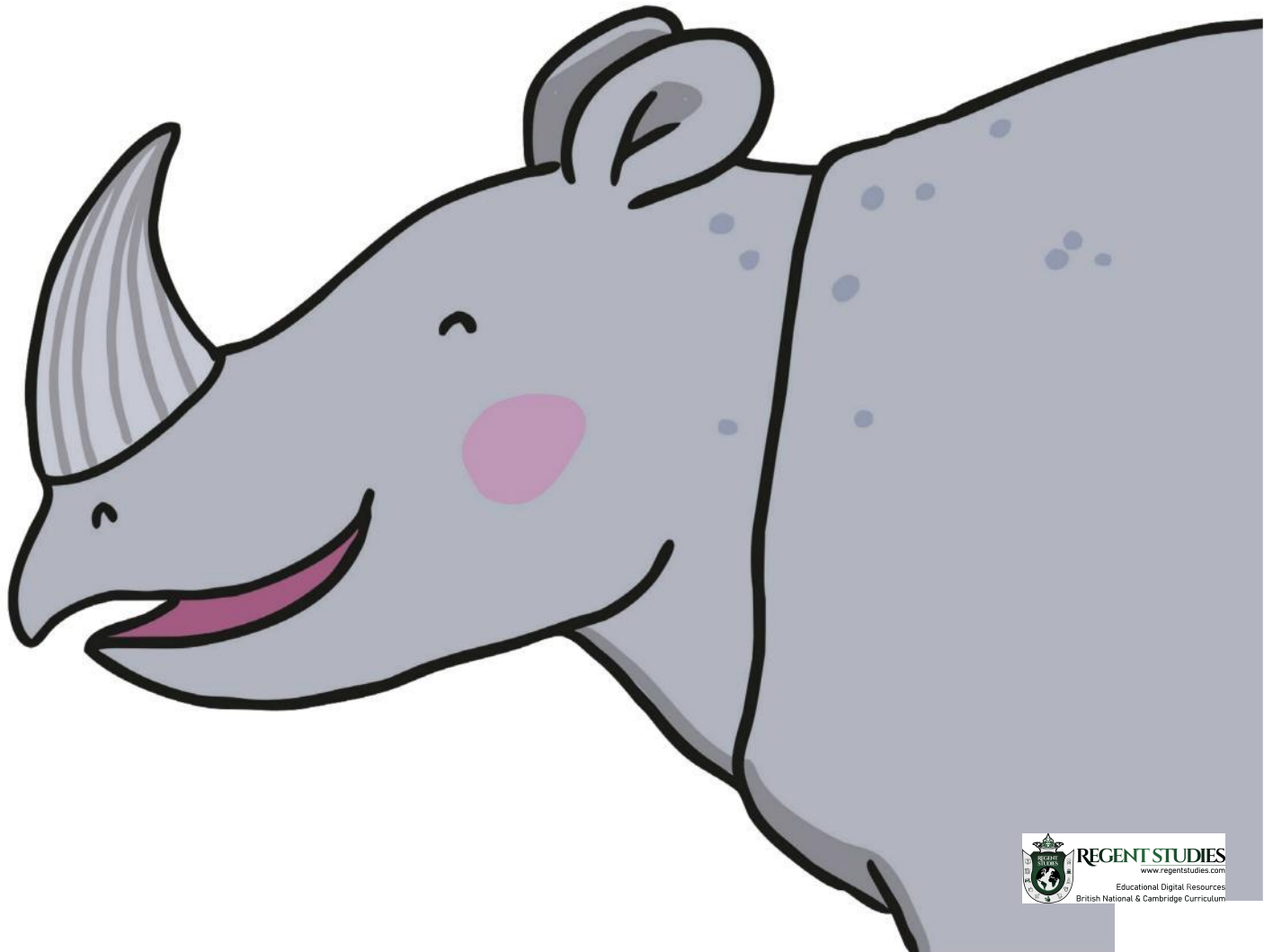

They come to a clearing, with few trees around,
With a beautiful stream; no one to be found.

Leopard says with a smile, "He lives just down there."
Across the wet ground, he approaches with care.

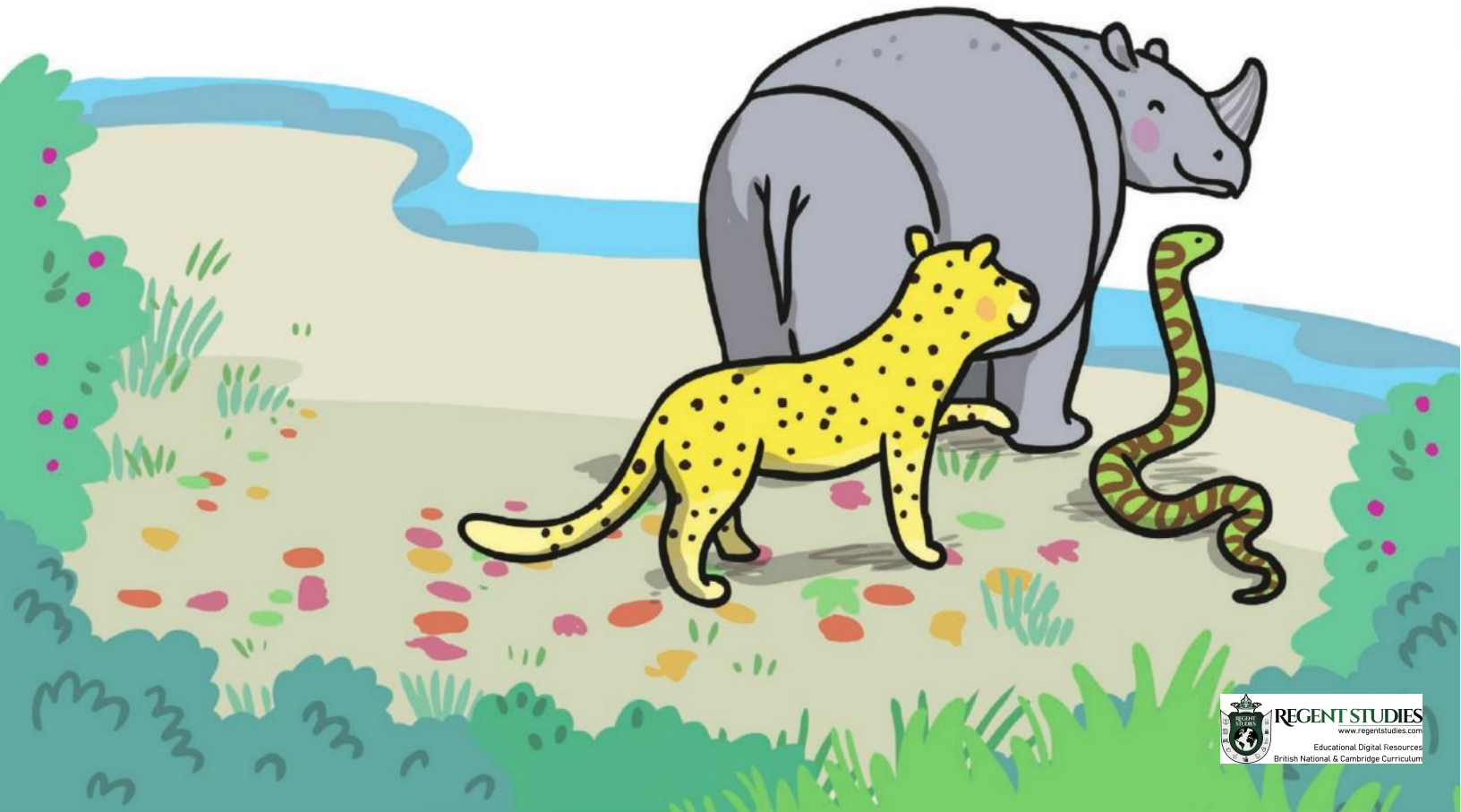

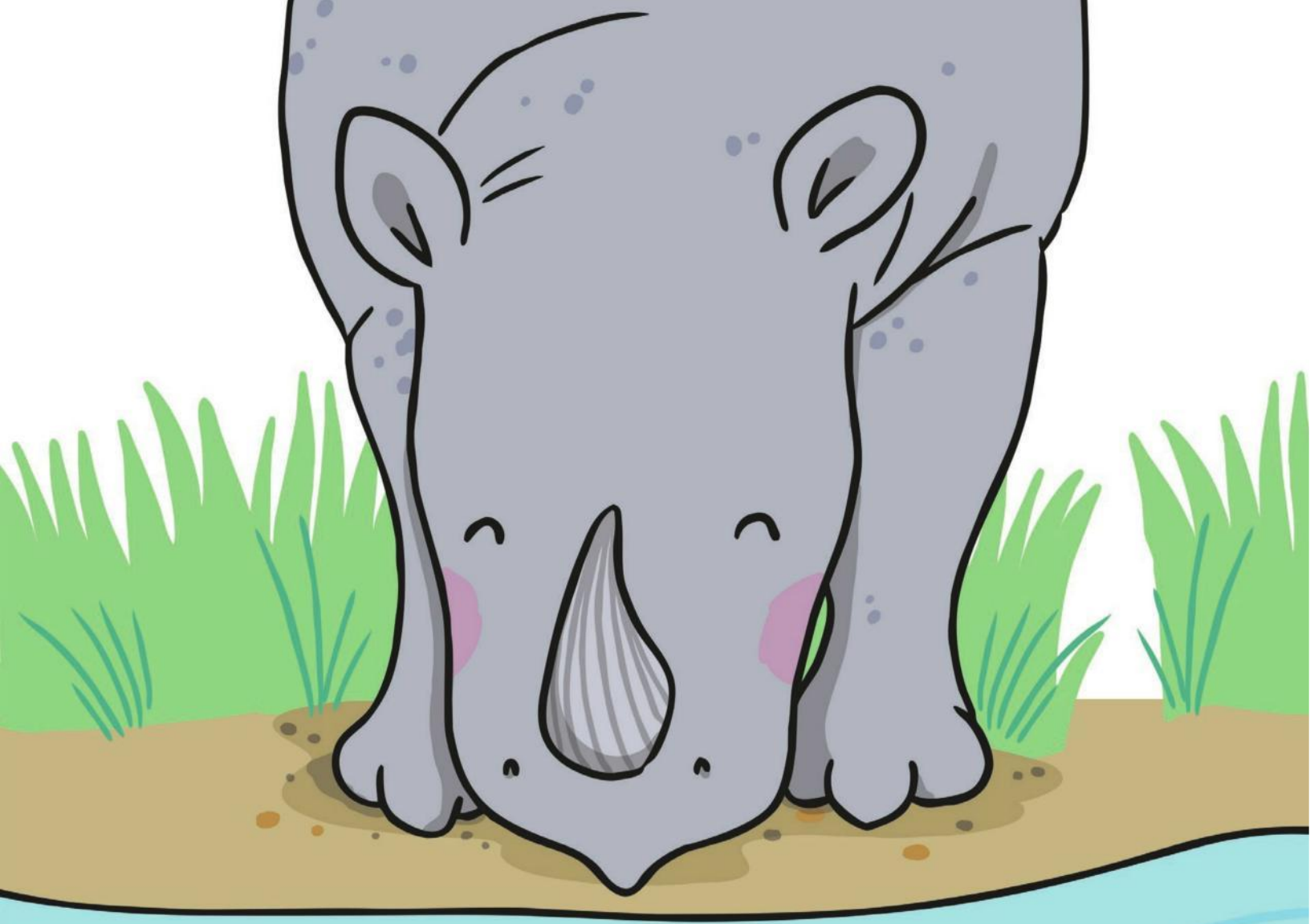

Ronald moves closer to look at this beast,
His heart all aflutter, his brow lined and creased.

He looks hard for a moment, his eyes flashing fast.
The water is silty with mud flowing past.

He stops as he sees it and then gasps out loud.
Leopard and Python could cry, they're so proud.

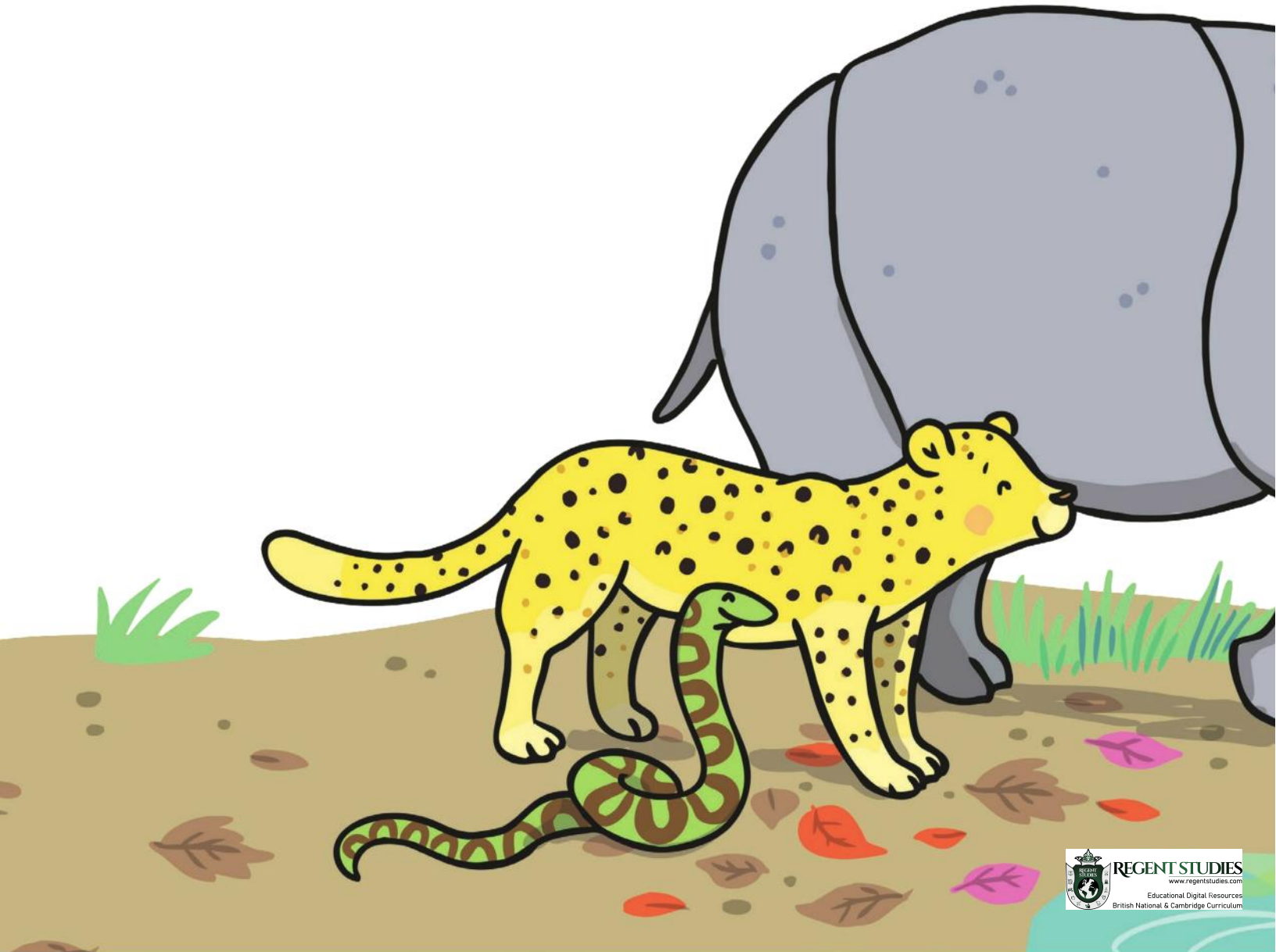

He grins at the animal that he can see,

“By golly,

It’s **amazing,**

It’s **wonderfully...**





...Me!"









Meet the wiggliest, jiggiest rhino in the forest!

“Ronald the Rhino is so big and strong.
In the Javan forest is where he belongs.”

Follow Ronald on his journey of discovery
– a powerful story about embracing
your uniqueness.

The Snail in the Rain

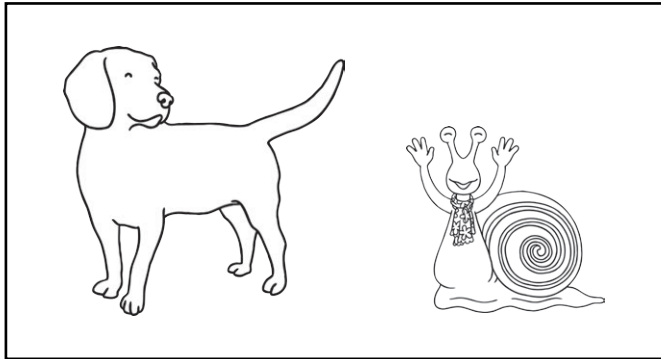

A contest was put on by the Queen, in spring. The snail and the dog with a tail, went to the start mark.

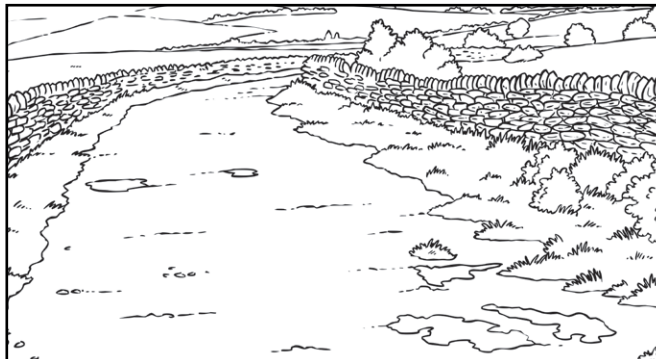

The aim was not to fail but to finish first. The main road was straight but full of bumps.



Then, the rain and hail fell from up high. The road was wet.

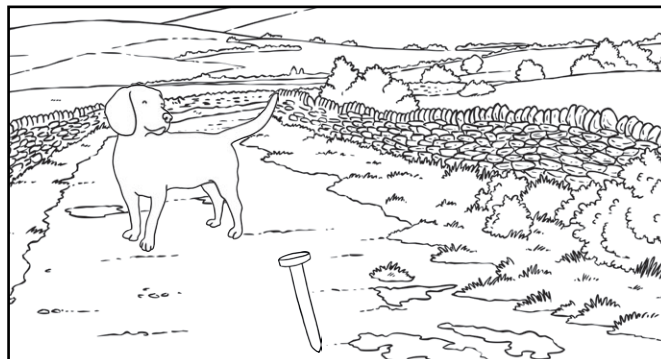

The dog fell on a nail stuck in the road. He was hurt and had to stop.

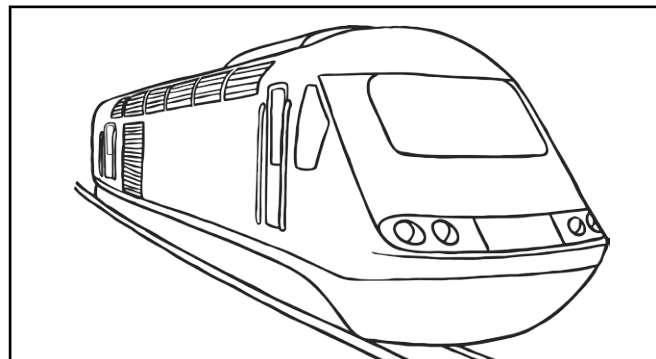

The snail felt bad. He went to pick up the dog. The dog was in pain. The snail put the dog on his shell and went to the train.



The train took them to the end of a rail track. They went to the finish together.

Clair at the Funfair

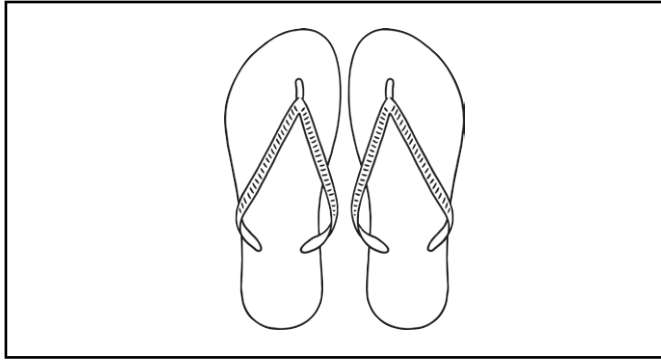

It was hot. Clair sat on a chair to put on a pair of red flip-flops.

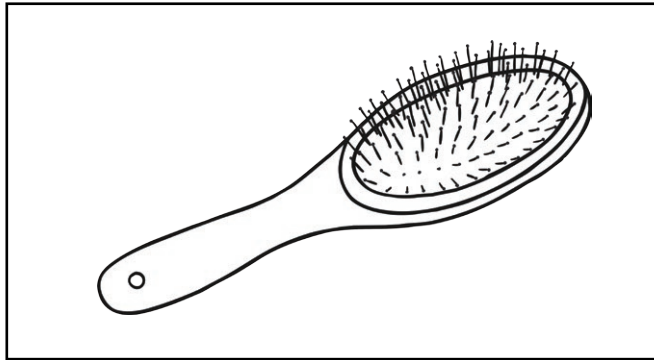

Then, she brushed her short hair and put in a clip.



After that, she set off to the park. Clair went to the funfair at the park. The fair was fun.

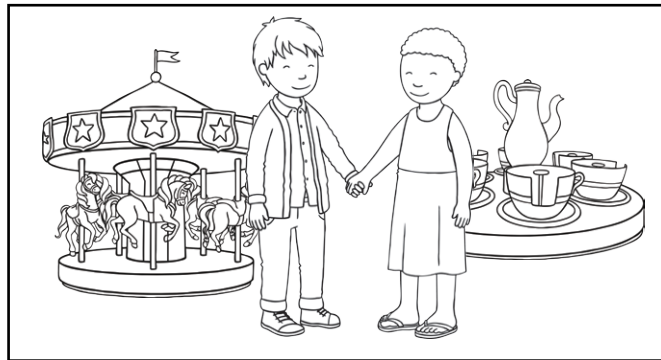

At the park, she met Gair. They went to get a ticket together. The fair ticket was silver.

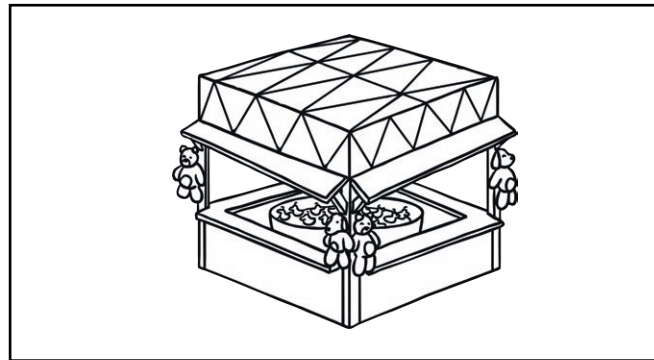

Clair and Gair had lots of fun. Clair went to the hook-a-duck. She got a duck and then a doll.



Gair had to finish at the fair, as his mum was waiting. He felt it was unfair, as Clair was still at the park. He might go back again the next day.

A Shark in the Park

Marvin and Arthur went to the park on a bright day. The park was not too far so they did not need the car.

At the park, the sun went in and it started to get a bit dark. Marvin and Arthur went to the far end of the park. In the pond, he spotted a fin. They went to the pond and there was a shark. The shark had a lot of sharp teeth and was swimming to Marvin and Arthur.

The shark swam to harm them so they left the park.



'ch' Phoneme Spotter Story

Chuck the Chick

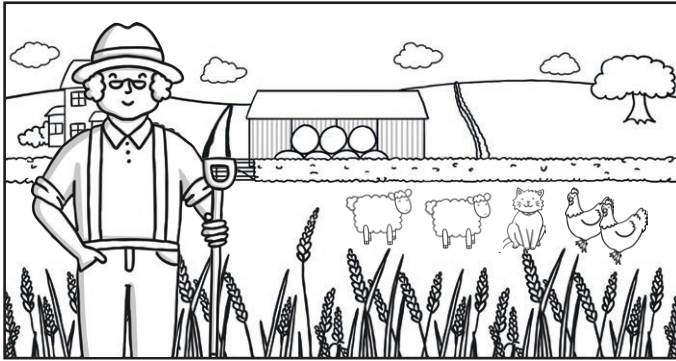

On a farm, near the coast, a farmer kept animals. He had dogs, cats, sheep, goats and hens.

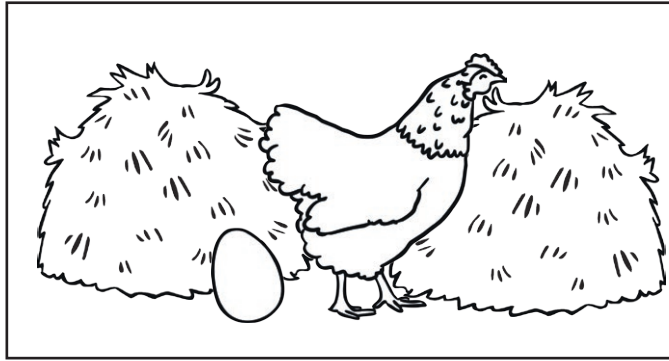

The hens laid eggs. In the winter, a red hen laid a big egg.

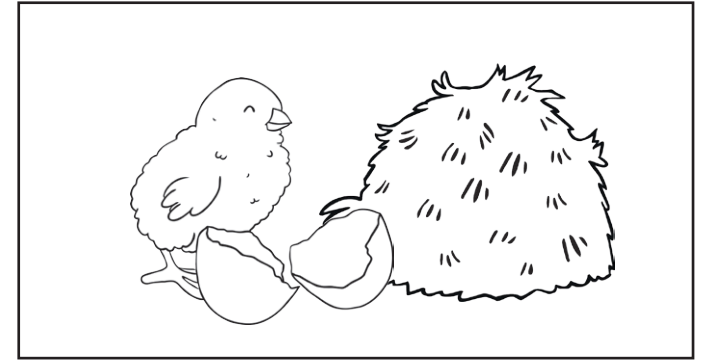

The egg got such a big crack in. In the egg, was a soft chick. Chuck was the chick. His mum fed him and got him a soft bed.

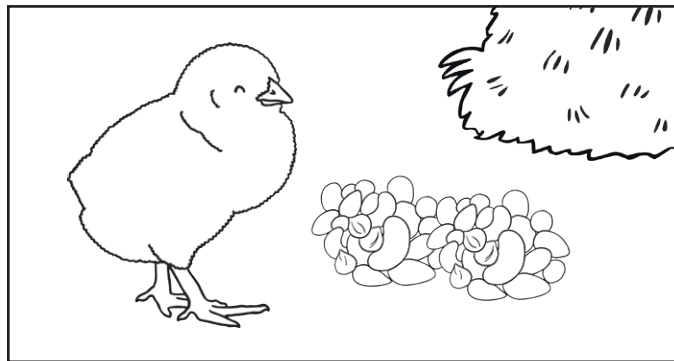

For his dinner, Chuck had seeds and nuts. The seeds and nuts went 'crunch'.

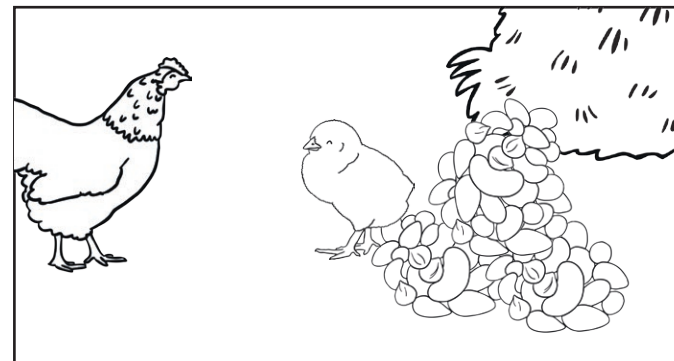

He had such a lot of food. His mum had to check he did not munch too much.

'Ear' Phoneme Spotter Story

The Meerkat With the Big Ears

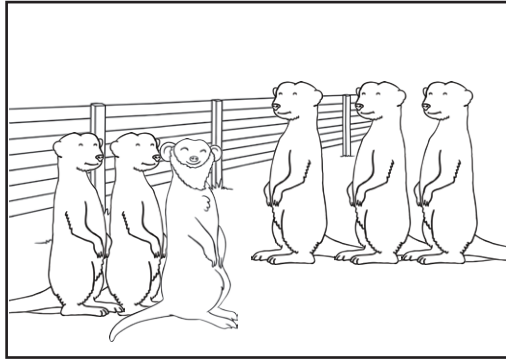

On a farm, stood a mob of meerkats.

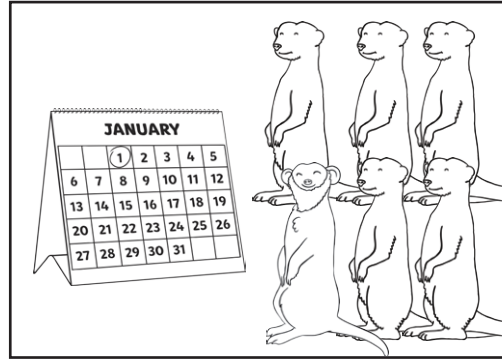

The six meerkats had been born at the start of the year.

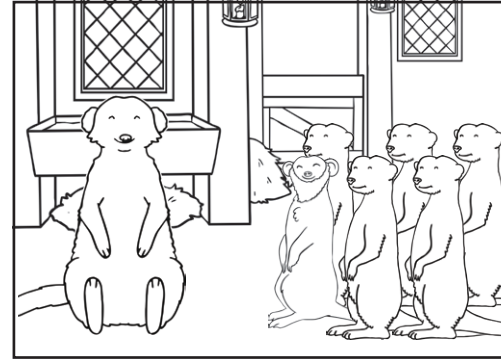

The mum had lots of meerkats in the barn.



The last of her meerkats had big ears and a beard.

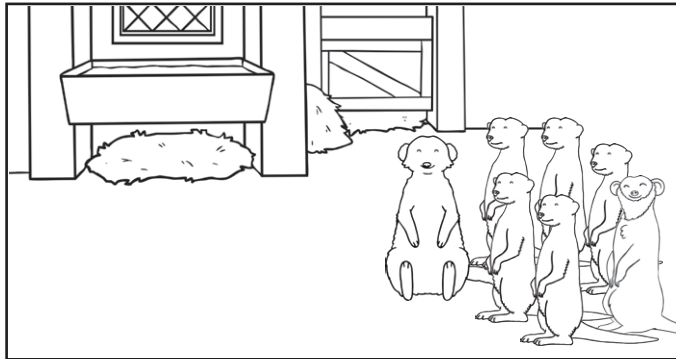

She kept them near to her, as it was a fear that they might get lost. At night, she put the meerkats to sleep at the rear of the barn. She then went to sleep.

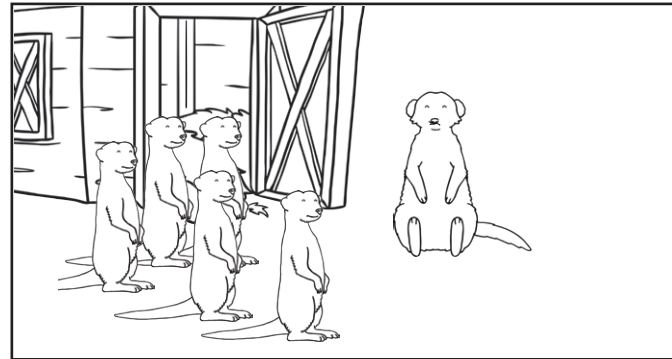

When it was light, the meerkat with the big ears and beard had disappeared. She shed a tear.



At night, the meerkat appeared, so she kept him near to her. She never put him at the rear, he had to be near.

A Real Treat!

Tom was very happy. It was the weekend and he was off to the beach with Mum and Dad, his puppy and baby Pete.

“Help me pack the green bag,” said Mum. “We need sun cream and lots to eat.”

Tom got into his seat in the back of the car and the puppy got on his knee. Pete held his toy sheep. Off they went. Beep! Beep!

At the end of the street there was a big truck. It had lost a wheel. “Oh, no,” said Tom. “We’ll be here for a week!”

Dad went to speak to the driver to see if he could help. They put the wheel back on. Then Dad said, “I must hurry. We need to get to the beach.”

At last they got to the sea. Tom and Pete had an ice-cream. Mum and Dad had a cup of tea. The puppy went to sleep under a tree.



The Mermaid in the River

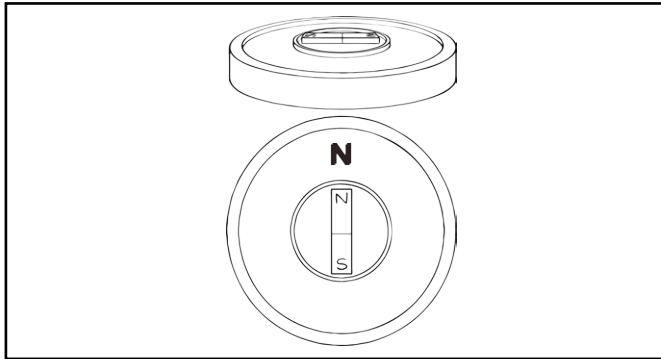

In the north, was a town. Perth was the town.

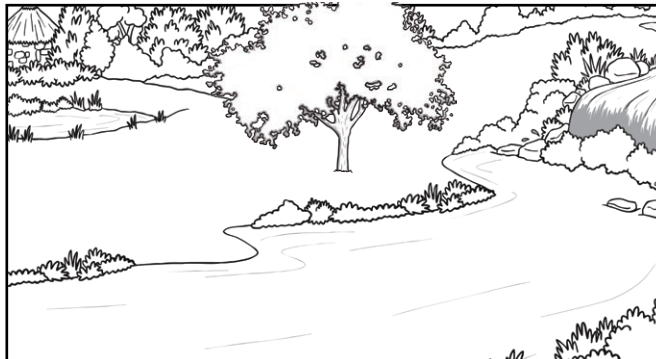

In Perth, was a river. The river was long and led to a rock pool.

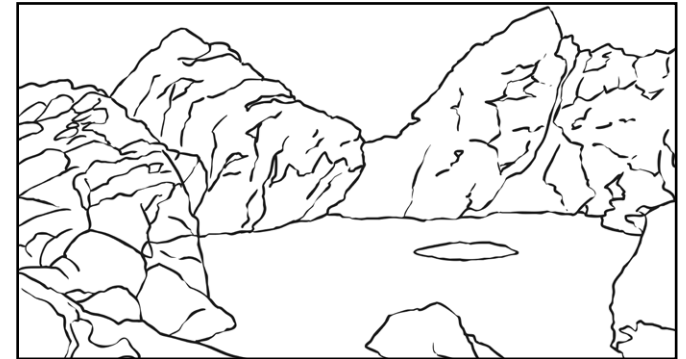

One day, in the winter, a man ran from the rock pool.



He had seen a monster. A monster with long hair and a tail. Her tail had greener fins than he had ever seen! Bernard did not go back to the rock pool.



After a number of weeks, Bernard's sister, Fern, went to see the monster.

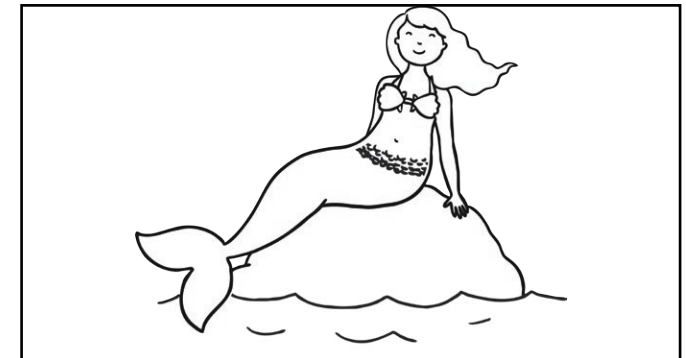

She went past the corner of the rock pool. A mermaid was next to a rock. She had a ring on her finger. She put herself on the rock. It was not a monster. It was a mermaid.

A Right Mess

The twins' bedroom was a right mess! Mum had tried everything. Being cross! Being kind! But it just did not help. The twins still did not tidy their room.

Then Mum had an idea. "I think I'll write a list of things the twins must pick up, and then we can play a game of hide and seek. The twins must find the things and put them in a box. Their room will be tidy!"

This is the list Mum had:

- A crisp bag
- A white sock
- A tie with a stripe
- A cap
- A plastic knife
- A bright red kite



"We like this game of hide and seek," said the twins. In no time at all the room was quite tidy and Mum was happy.

Then the twins had an idea. "Mum, we'd like to fly this kite on the green."

"All right," said Mum, "but you must hold the string tight."

On the green there was a light breeze and the kite went up, up, up, high in the sky. Then suddenly it came down, down, down...

CRASH! It fell into the duck pond!

The kite was fine, but Mum said, "I think it's time for tea. Let's go home."



The King and the Ring

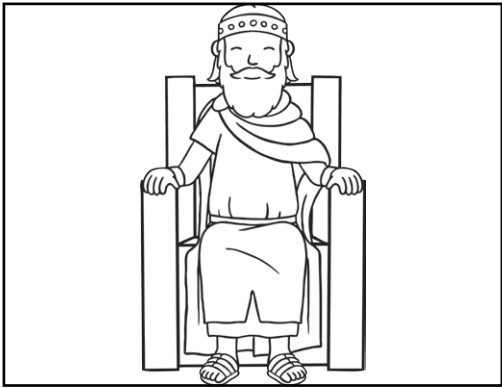

Long ago, King Bing had lots of silver rings and chains. Bing had spent a lot of coins to get them.

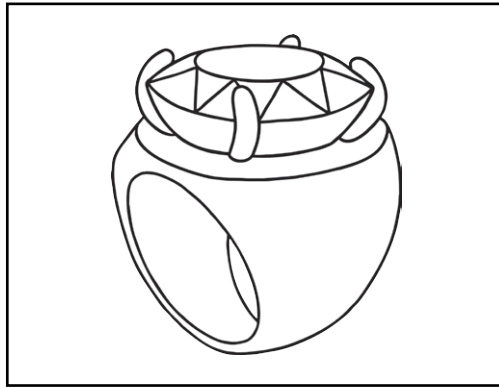

His best ring was bright red. He put a cloth on it to polish it.

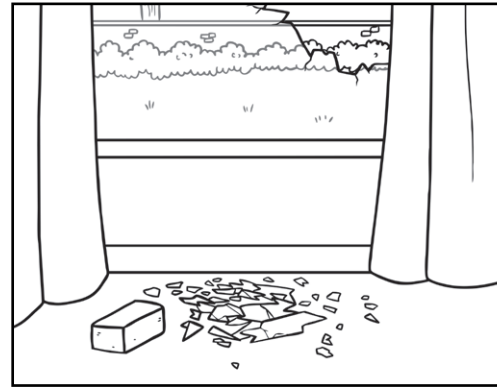

On a dark night, a gang put a brick in the glass. The glass went 'bang!'



The men got in and took the ring from the cabinet next to King Bing. In the morning, King Bing got up and was upset. He had lost his best ring.

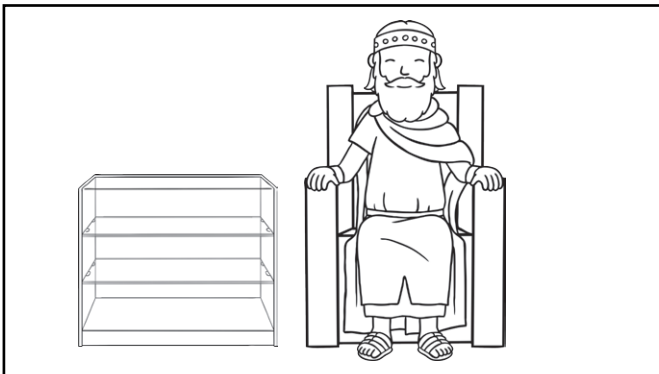

King Bing was sad for weeks. He wished to have the ring back.

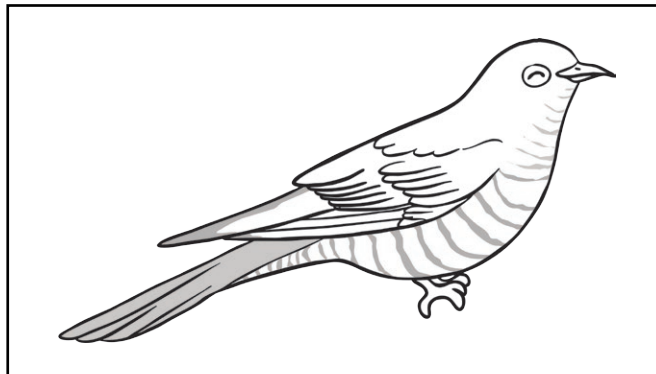

The next morning, a cuckoo put the ring on his wing. He put the ring back in the cabinet.

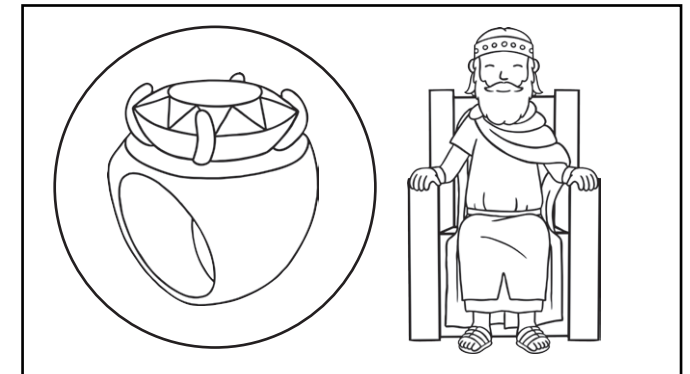

The king got up and the ring was back. He put it on his finger. He was glad. He never took it off again.

The Old Pony

Joe, the old pony, was in his field. He was so old and slow that nobody rode him anymore. The wind was blowing. He felt cold and lonely.

Just then, Jazz and Hal rode by on their bikes. They were going home for tea. They felt so sorry for old Joe that they stopped to stroke him.

At teatime they told Dad about Joe.

“Don’t worry,” said Dad. “I know I can help him.”

After tea, Dad went to the shed and got an old green coat and a thin rope. Jazz and Hal got the end of a loaf of bread.

“Let’s go,” said Dad.

Dad and Jazz and Hal went back to Joe’s field.

“Hello, old fellow,” said Dad. Quickly, he put the old coat over Joe’s back and tied it on with rope. In no time at all, Joe was as warm as toast!

Jazz and Hal gave Joe some of the loaf to eat. Old Joe was happy at last.

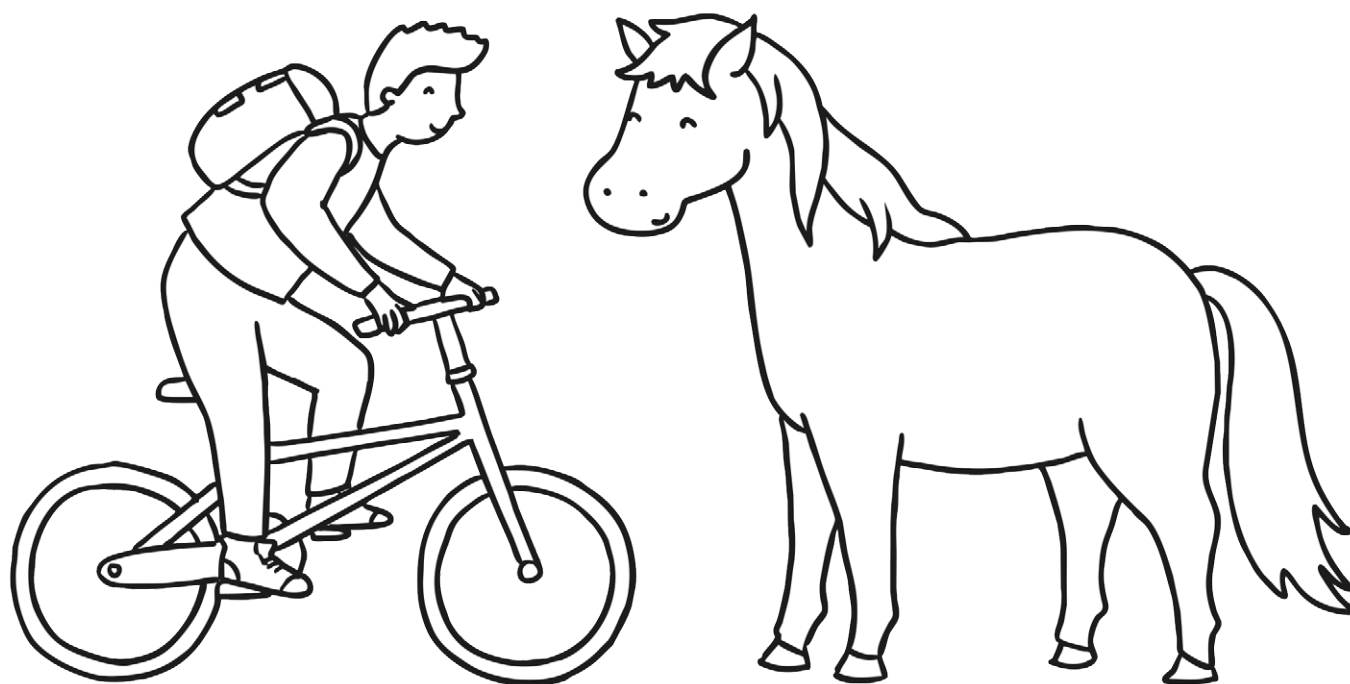

Sorting Sheet Activity

Can you write all the 'oa' words you spotted?

Can you sort the words you spotted into different spellings on the 'oa' phoneme?

Can you write all the 'oa' words you spotted?

Can you sort the words you spotted into different spellings on the 'oa' phoneme?

The Coin in the Soil

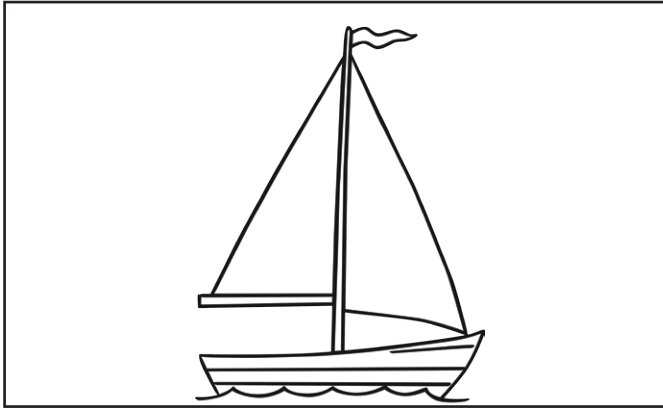

Long ago, a boat with a pointy mast set sail.

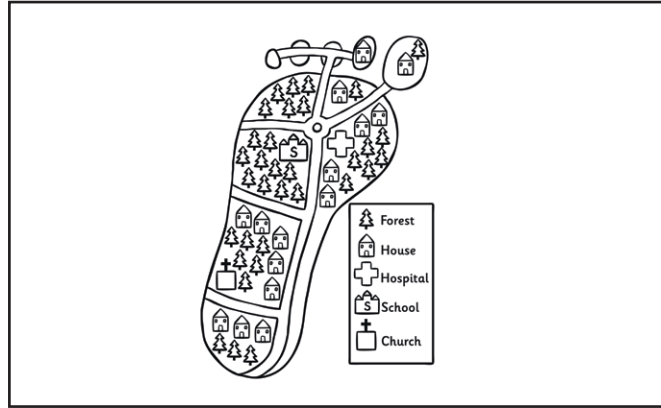

The men on the boat were looking for a land called Poin. They had heard that there was gold there.

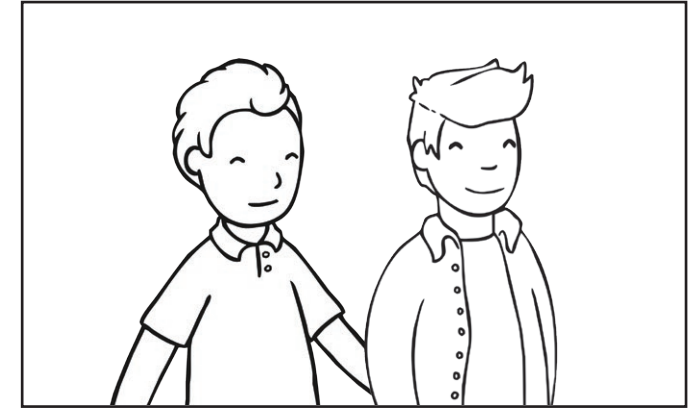

Jack got off the boat and went to look. Bob went to join him.

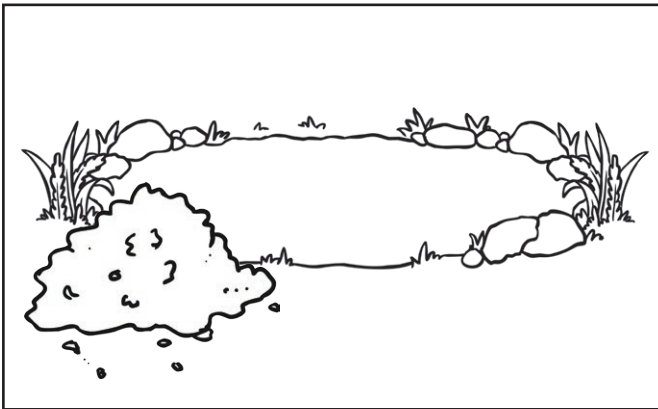

They saw a pond. Next to the pond was a pile of moist soil. Hidden in the soil was a gold coin.



On top of the soil, was a jar of poison.

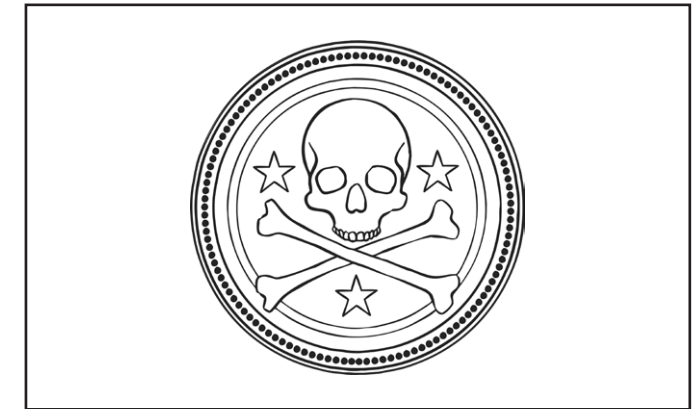

Jack and Bob did not want to spoil the coin with the poison. So they got a stick with a point and they used it to get the coin. Then they wrapped it in foil and took it home.

Keeping Cool

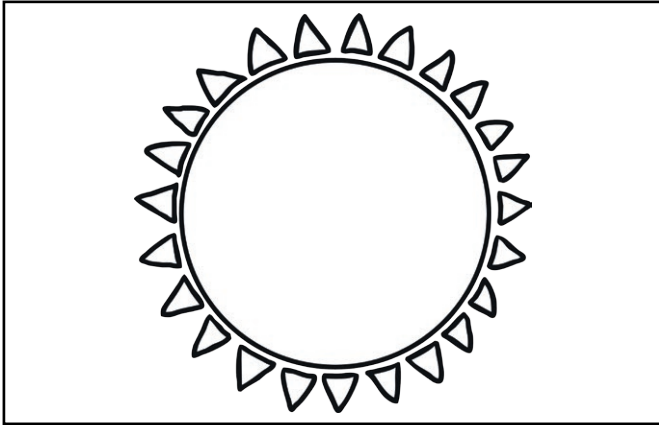

It was summer. It was getting hot.

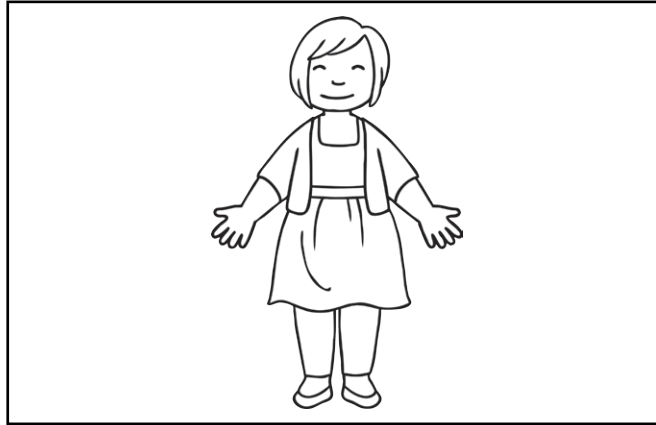

Jools had fair skin. She had to look after herself if it got too hot.

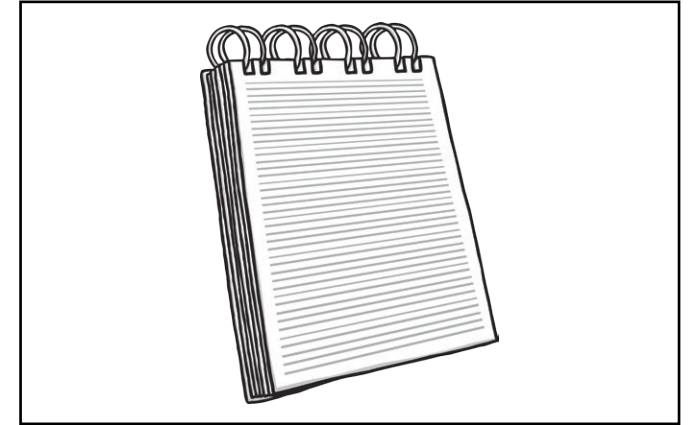

Her mum put up a list of tips in her room.

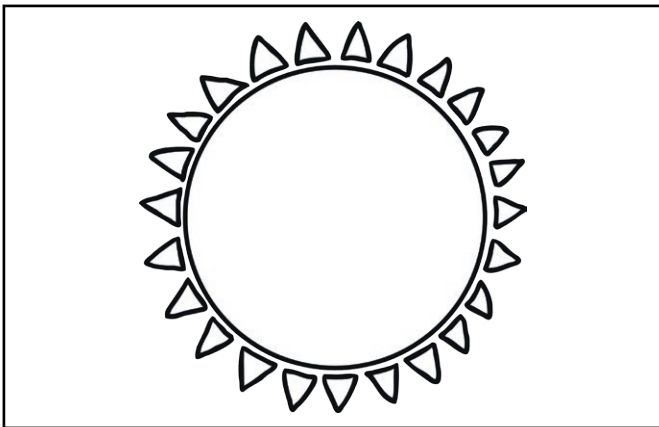

You must not go in the hot sun from 12 until 3.

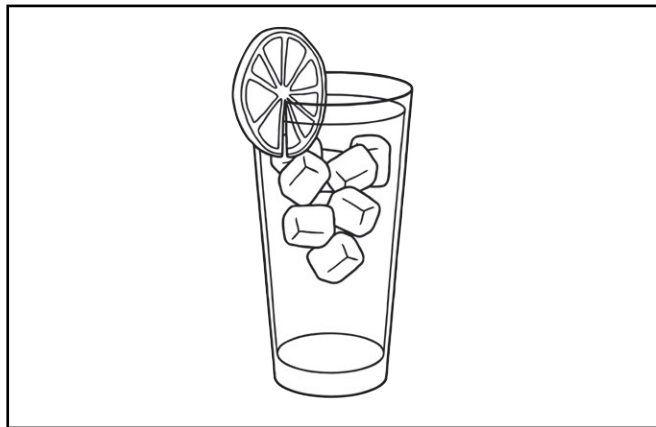

You must drink lots of cool drinks.

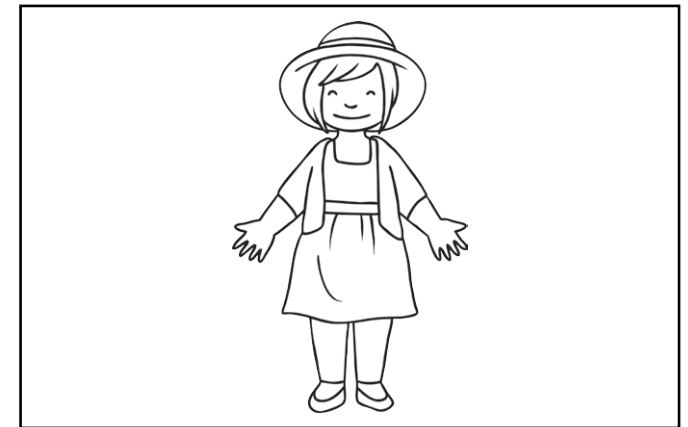

Put a hat on to keep the sun off you.

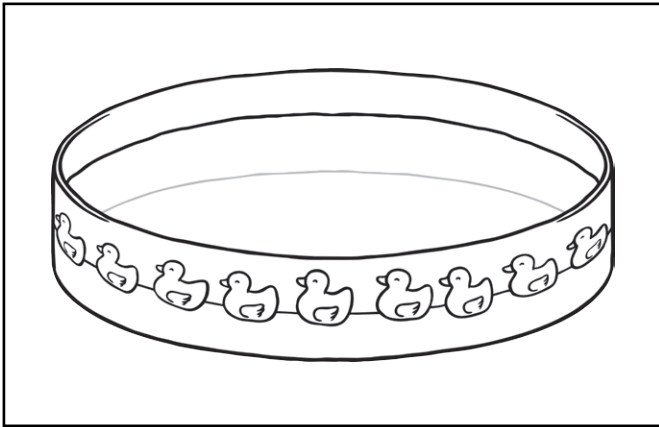

Cool down in a splash pool.

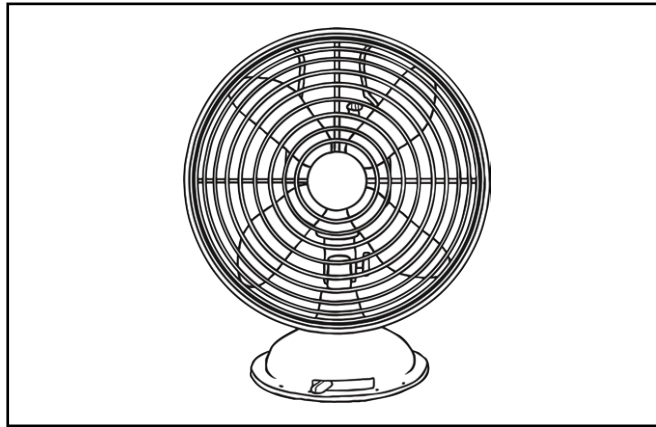

Put a fan next to you.

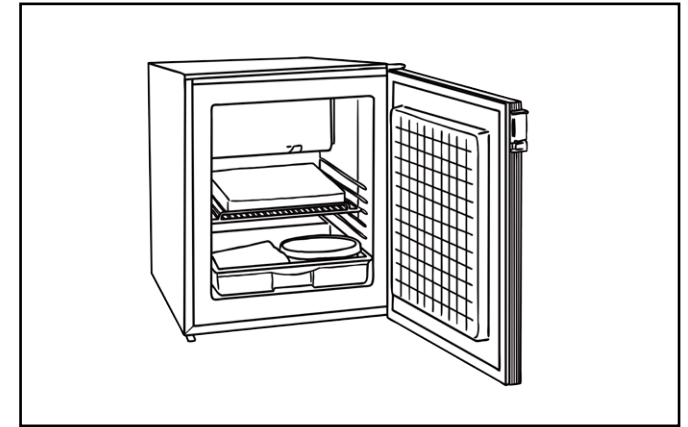

Get cold food from the freezer.

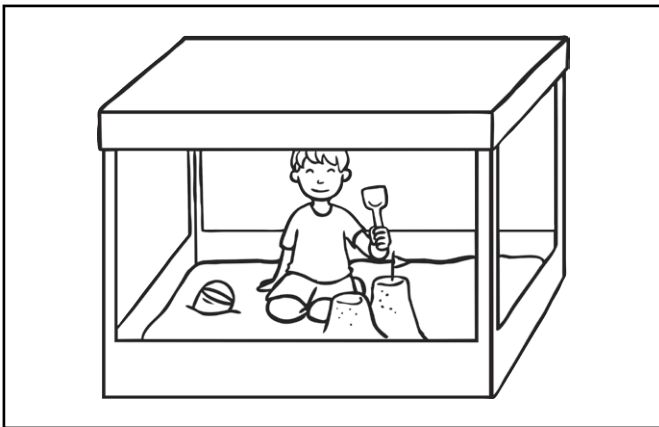

Sit under a roof, not in the hot sun.

The Cook in the Wood



Deep in the dark woods, was a person. This person had not been seen for years.

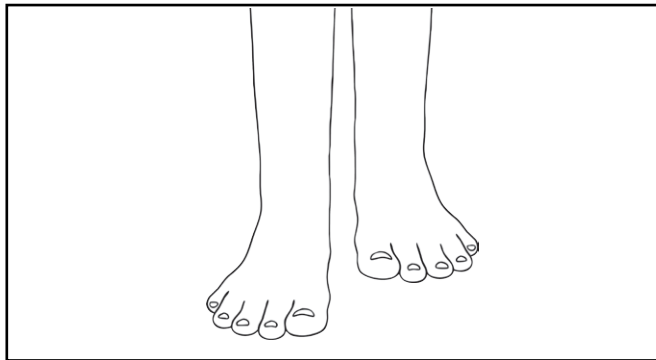

She had a good foot and a bad foot so she had to hop.

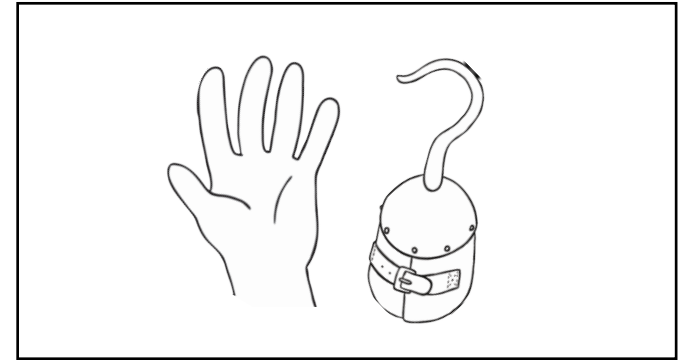

She had a good hand and a bad hand. In fact, her left hand was a hook. This hook had been on her arm for fifteen years.

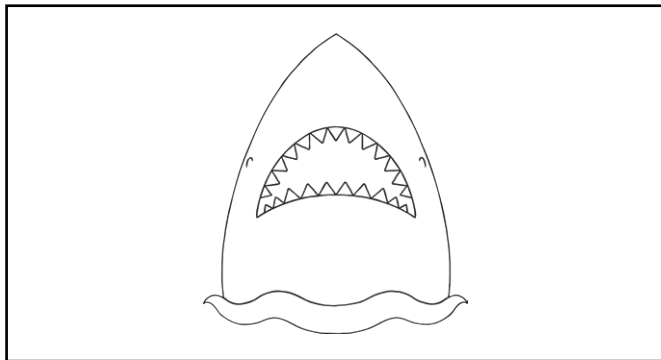

Fifteen years ago, a shark bit her hand off!

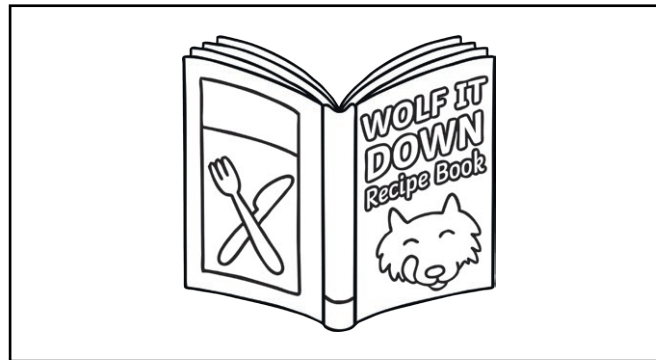

In the woods, she was sad. To cheer herself up, she was a cook. She was a good cook. She had some books too. Her best book was a cook book.

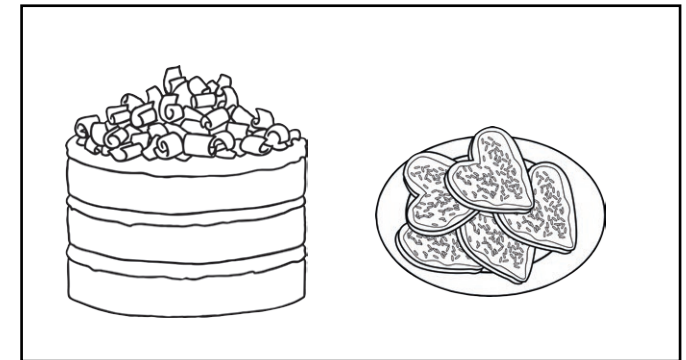

She cooked good things and sent them to shops for them to sell.

The Unicorn

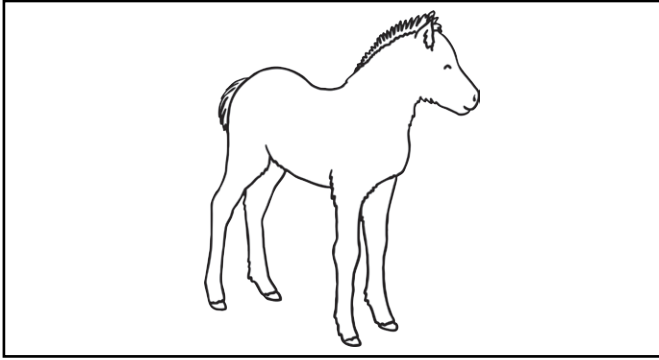

Up in the north, near to York,
was a foal.

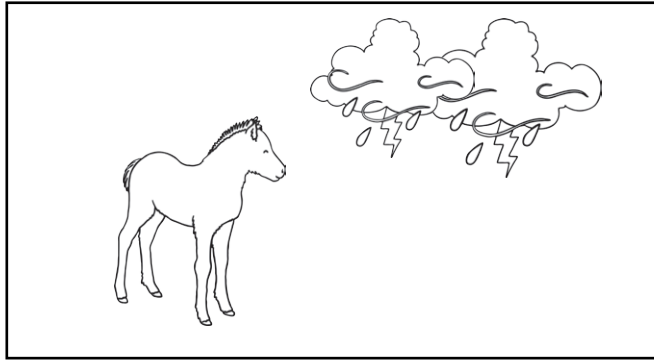

On a wet night, in a storm, the
foal was born.



A vet went to help.

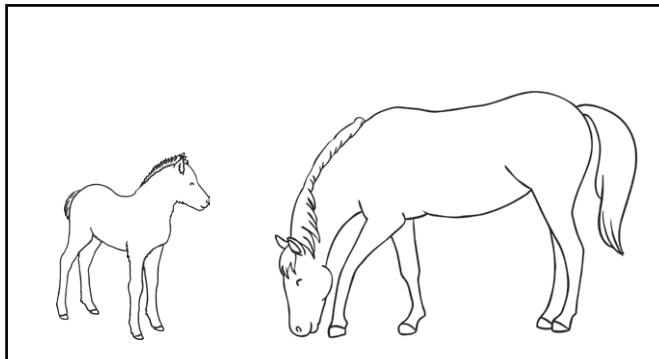

The foal was a bit different. He
was short.

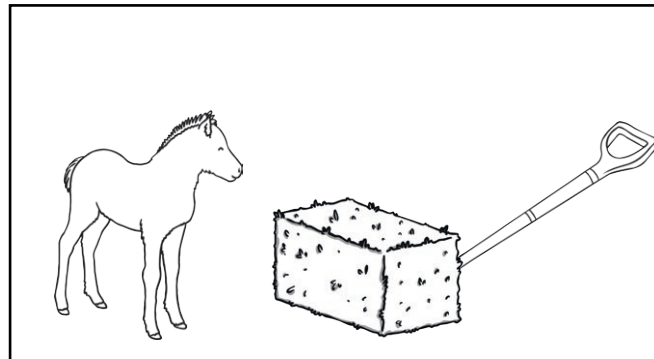

They fed him food with a fork to
help him get bigger. He did not
get bigger.

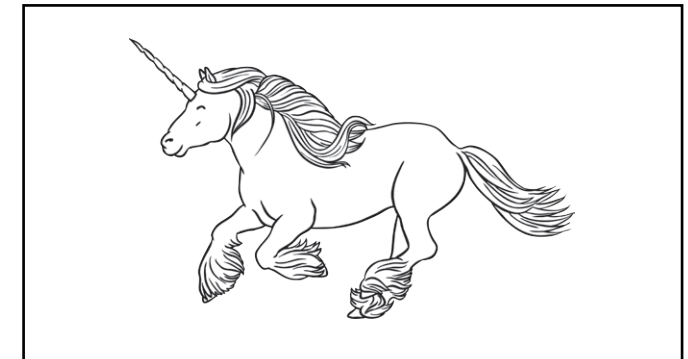

After that, the foal got a horn. He
had a big horn. In fact, he was not
a foal, he was a unicorn.

The Fox and the Owl



In the big, green wood, was an owl and a fox.

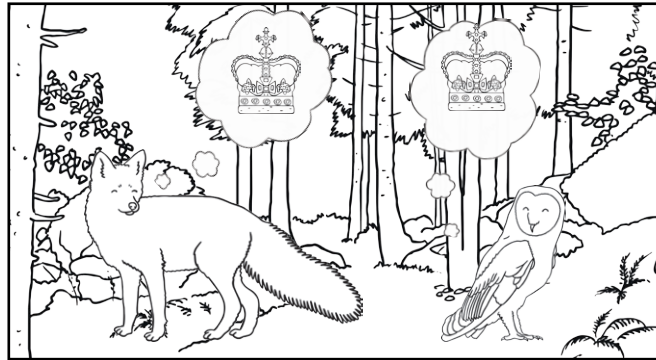

The owl and fox wished to be king. All of the animals gathered together to pick a king.

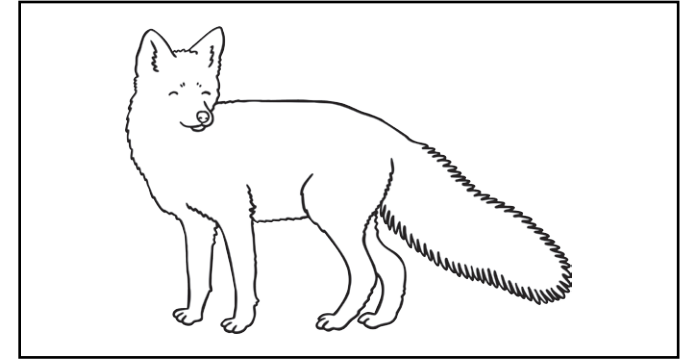

“I will be the best king, as I am strong and clever. I am better than the owl. You cannot pick him!” yelled the fox.



“I can swoop and look and see all the town from up high,” went the owl. “Let me be king.”



The animals had to pick a king. It was hard. A shower of rain fell from up high. With the shower, was a verdict.



The owl was going to be king, as he did not boast too much. He was given a crown and a gown. The animals all bowed to him.

Sh Phoneme Spotter Story

Shane the Shark was swimming through the sea. He was looking for his friend Shelia the fashionable mermaid but could not find her anywhere.

“Are you hiding by the shore?” he shouted, but there was no reply. “Is that you in the shallow water?” he called, but all Shane could see were jellyfish. “I wish I could find you,” sighed Shane in a hushed voice.

Shane heard a strange sound, “What’s all that commotion?” he thought. He swam closer and saw lots of crabs with a bubble machine! “Would you like to play?” asked one of the crabs. “Not today thank you,” replied Shane “I’m on a mission to find Shelia.” “Okay, if you’re sure. I’ll send you an invitation to my bubble party,” replied the largest crab. “Thanks, see you soon!” smiled Shane.

Just then he saw a strange shape. It looked suspiciously like a giant fish but it was just a shadow of a passing ship. The water moved like a water chute as the ship dashed past.

As he swam quickly away, Shane saw something shimmering and glittering in the sand. He swam closer for a better look. It was a group of shiny shells! Shane picked up a shell and then heard a splash - it was Shelia!

“Where were you hiding?” he shouted as Shelia dashed past him. “I had to wash my hair,” she giggled “I used lots and lots of shampoo. Look at all the shiny bubbles!” As Shelia swished her hair, a shower of bubbles whooshed through the water and popped on Shane’s sharp teeth!

Shane and Shelia had lots of fun jumping and splashing in the sea. They shared some delicious seaweed mash with sugar on top and a milkshake before Shane had to go home. “See you tomorrow,” he shouted as he swam away. “I will show you the shipwreck and we might see some starfish too!”

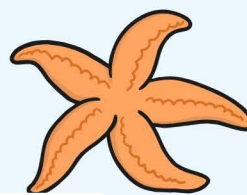
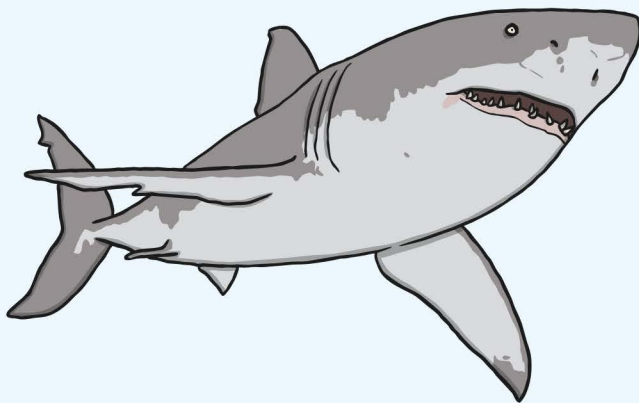

REGENT STUDIES

www.regentstudies.com

Educational Digital Resources
British National & Cambridge Curriculum

Beth and Cath

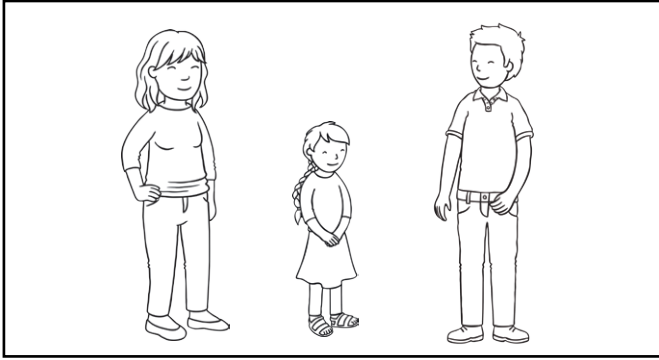

Beth has a mum and a dad.
Her mum is Thelma and her
dad is Seth.

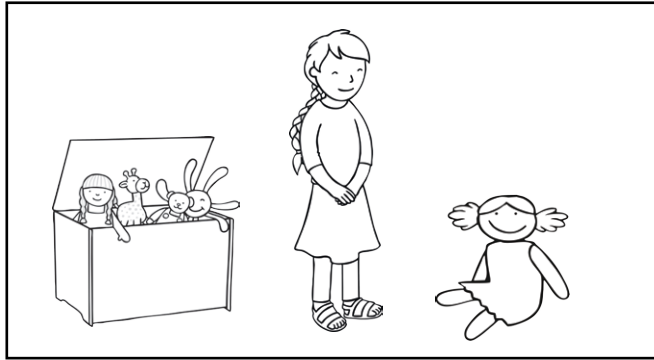

Beth is three and she has fun. She
has fun in her bedroom with her
things. Her best thing is a doll.
Cath is the doll.



She has thick hair and it is soft.

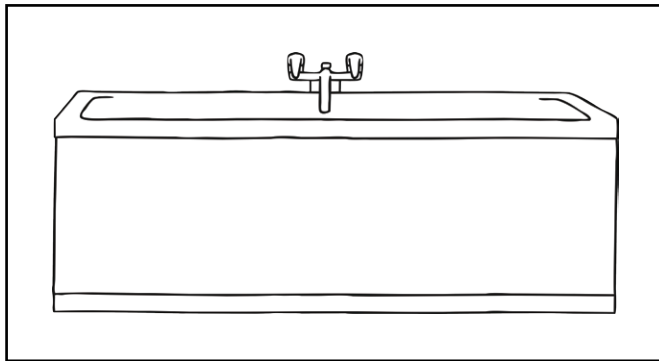

At night, she gets in the bath.

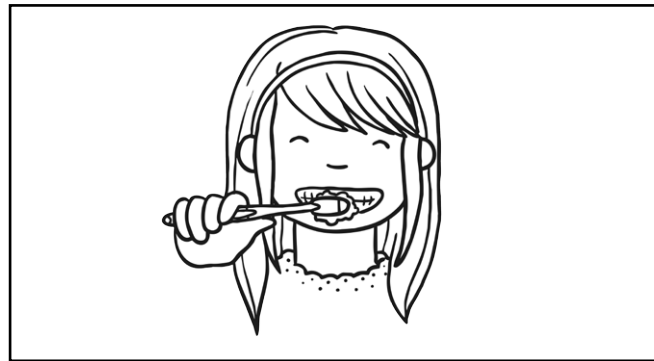

After the bath, her mum helps her
to brush her teeth.

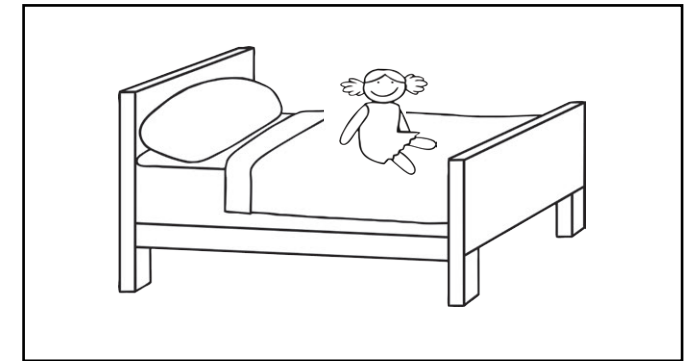

Then, she sleeps in her bed with
her doll, Cath.

Phase 2: Tricky Word Spotter Story

The Church

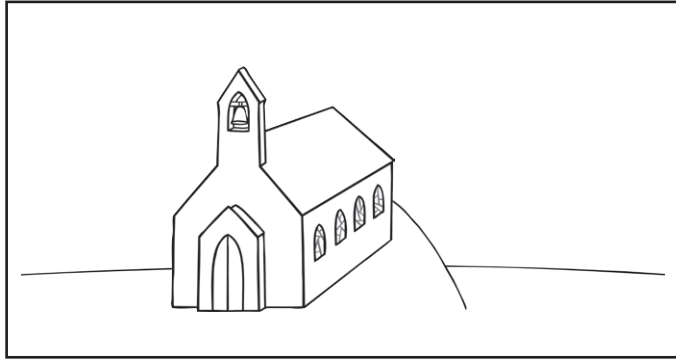

On the top of a hill stood a church.

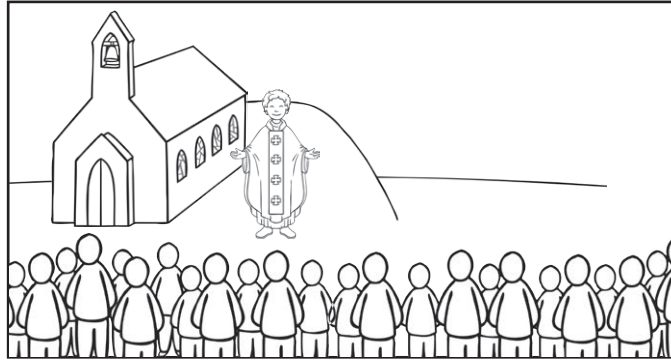

The church had lots of visitors,
as the vicar was a good man.

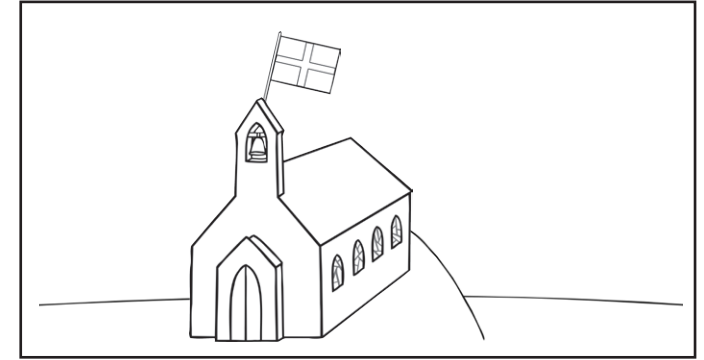

On the top of the church, was a flag.
The flag was seen from afar.

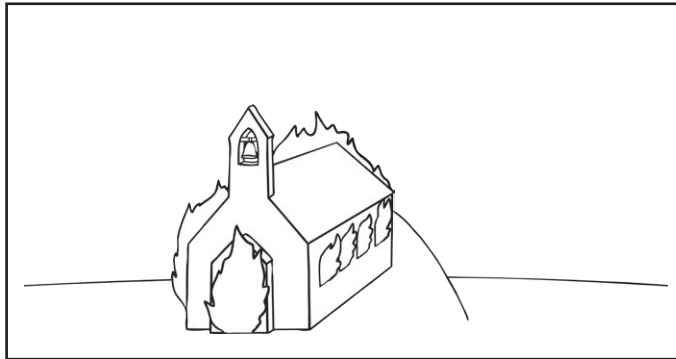

One sad weekend, the church burnt
down but no one was hurt.



Then, the vicar had a garden fair.
The vicar needed coins to help the
church, as it had burnt down.

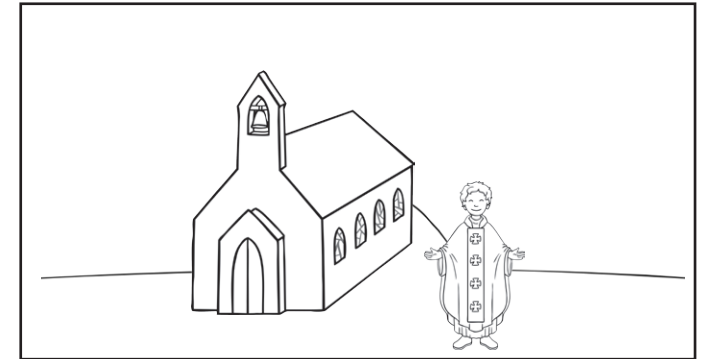

The church got help. The vicar got
lots of coins. The church was put
back up again.

The Mixture in the Picture



Hure was ill. In fact, he kept being sick. He had a temperature and felt too ill to get up from his bed.

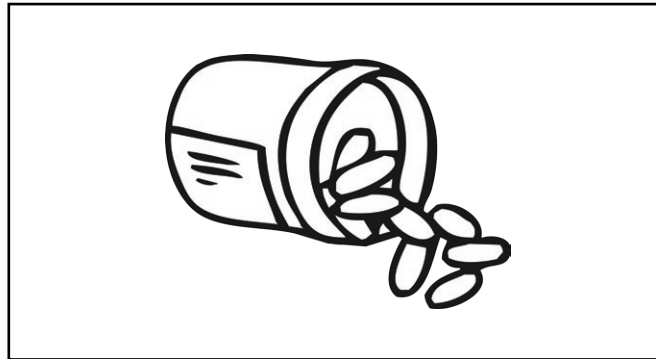

The doctor sent him to bed with a pill. The pill did not help Hure and he still felt ill.

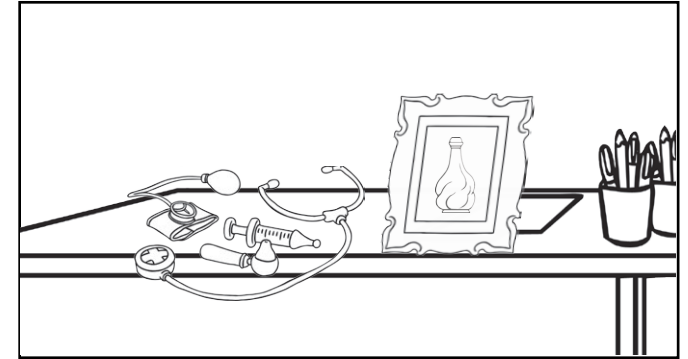

He went to see the doctor and sat in his room. In the doctor's room, on his desk, was a picture.

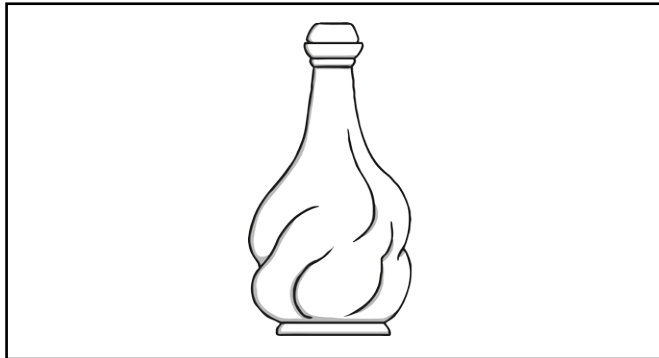

The picture was of a mixture that was pure green.

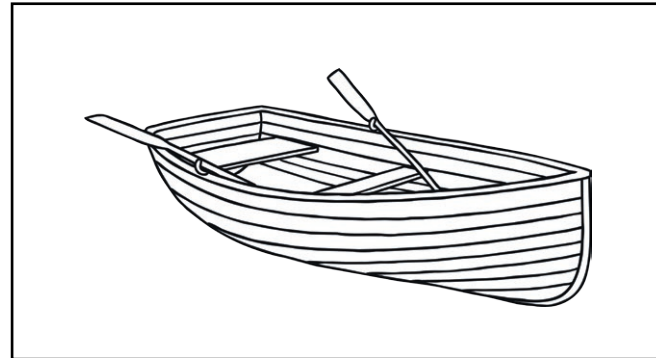

He had to get the mixture to cure him. The doctor went by boat and got this mixture.



"You will now get a cure!"
Hure drank the mixture. He had his cure.

Bex and the Box



Bex was cheerful.

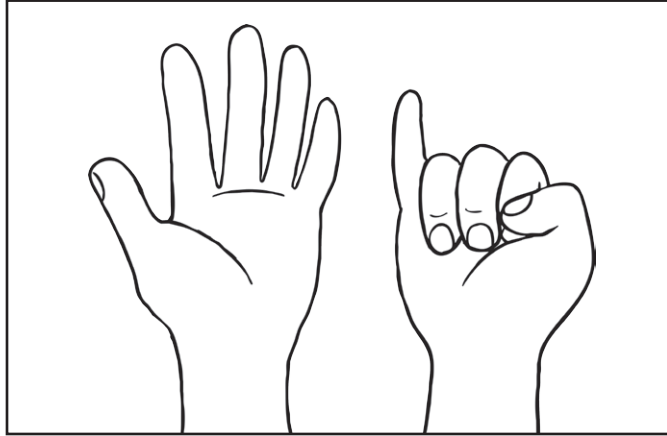

She was six.

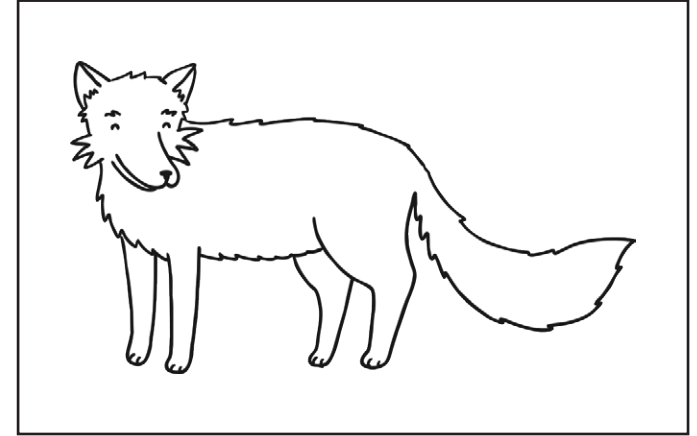

At night, a fox crept into her garden.



Bex did not think the fox was good. She was afraid.

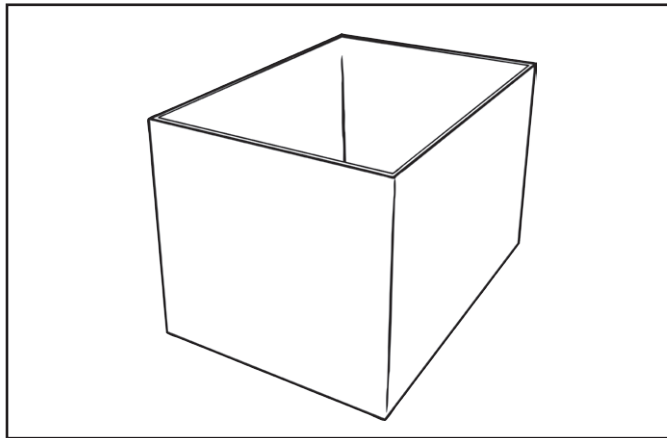

She got a brown box.

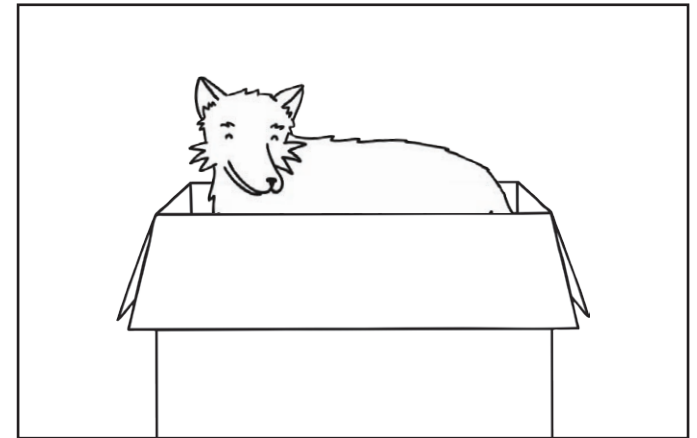

Bex put the fox in the box and took it to the vet.

Yasmin the Yak

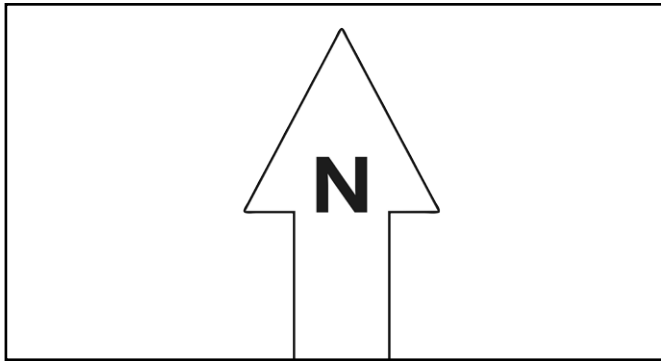

In a town up north,
it was freezing.



The town was York.

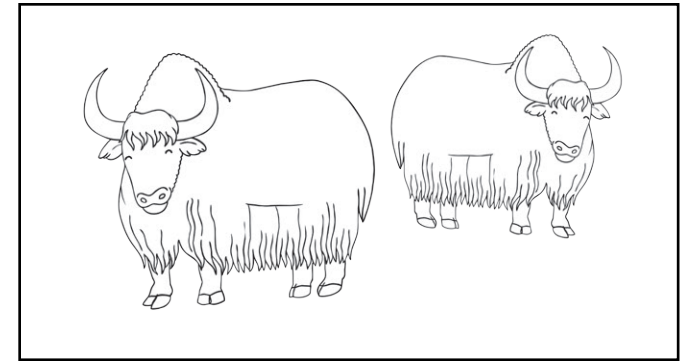

In the last year, yaks had fled
to York.

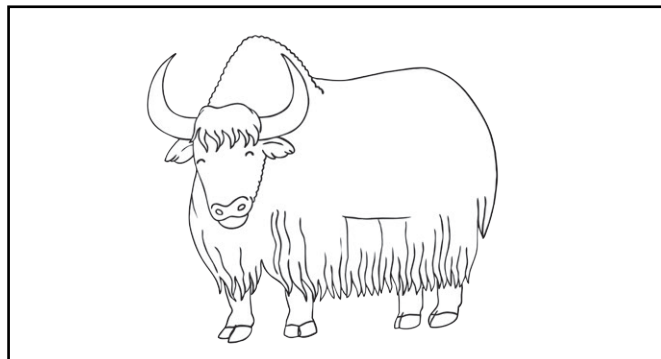

The yak with long hair
was Yasmin.

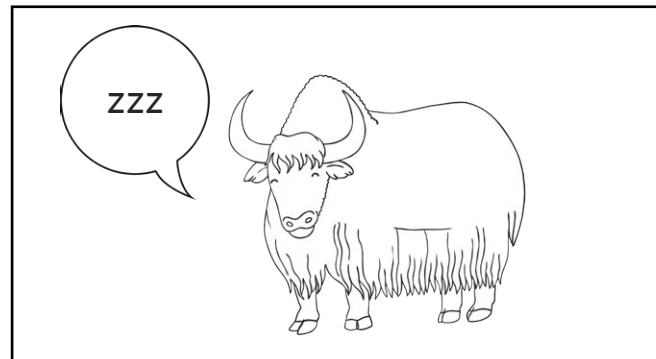

Yasmin had been on a
year-long trek.

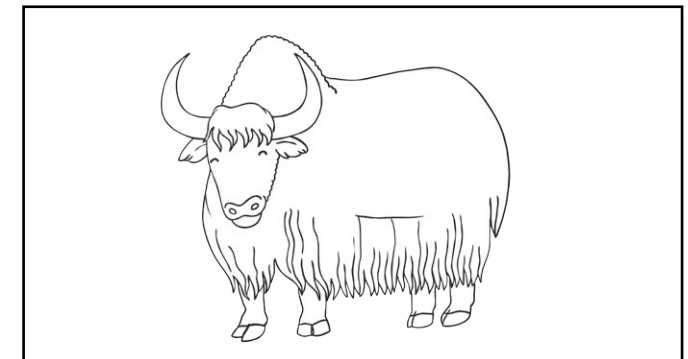

Yasmin needed to rest,
so sat down.